

# SP40 801

12NC: 859991530890

GTIN (EAN) code: 8003437042331

# Whirlpool

SENSING THE DIFFERENCE

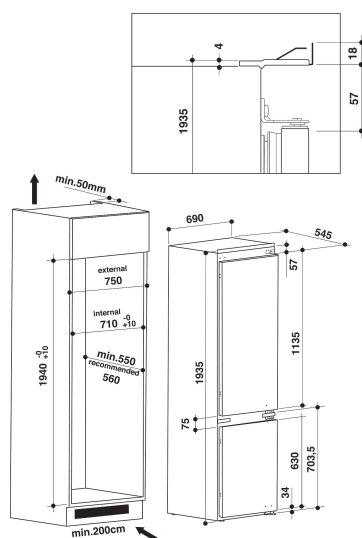

- Energy class A+
- 6TH Sense FreshControl
- Total net capacity: 400 l (299 l refrigerator + 101 l freezer)
- Product dimensions (HxWxD): 1935x690x545 mm
- Reversible door
- Noise level: 35 dB(A)
- StopFrost
- Fast cooling
- Fast freezing
- Climatic class SN-T
- Freezing capacity: 4.5 Kg/24 h
- Fast Freeze Compartment
- Door alarm
- Temperature alarm
- Automatic defrost system
- Temperature rise time 26 h

## Whirlpool built in fridge freezer - SP40 801

This Whirlpool built in Fridge Freezer features: white color. A tall appliance to fit your family needs. Glass shelves, providing both robustness and elegance. A fan that provides a smooth and even flow of air in your appliance's cavity, for enhanced ventilation. Unique 6th SENSE FreshControl technology, that automatically adjusts temperature and humidity levels inside your appliance, ensuring long-lasting freshness.



### LessFrost

Forget frost formation. The innovative LessFrost technology features a unique evaporator wrapped around the freezer cavity, rather than in between the freezer drawers, to ensure a drastic reduction of frost formation.



### Fresh Control

Fresher, for longer. The unique 6TH SENSE Fresh Control technology dynamically adjusts the humidity levels and temperature inside your freezer, to ensure long-lasting freshness (up to 4 times longer).



### Freeze Control

Care-free freezing. This Whirlpool Freezer features the innovative FreezeControl technology, that effectively protects your food's taste and texture, and reduces freezer burns by up to 50%.



### 380 - 430 l capacity

All the space you need. This Whirlpool fridge-freezer combination is designed to provide all the space you need to comfortably store your food and drinks.



### STOP FROST

1-minute defrosting 1 time a month. Forget ice build-up in the top of your food and in the lateral sides of the freezer, with the StopFrost system. To defrost, simply remove the ice-collector on the top part of the freezer and rinse it under the tap for 1 minute, once a month.



### Energy class A+

Outstanding energy efficiency. With its A+ energy rating, this Whirlpool appliance will allow you to enjoy both ideal performance and excellent energy consumption.



### Everest

The Everest fridge provides unparalleled storage space.



### Fast freezing

Fast freezing. The Fast Freeze function sets the freezer temperature to 10 degrees colder than the lowest setting, to freeze food quickly and retain its nutritional values.

# SP40 801

12NC: 859991530890

GTIN (EAN) code: 8003437042331

# Whirlpool

SENSING THE DIFFERENCE

## MAIN FEATURES

Product group	Fridge/freezer combination
Installation type	Built-in
Type of control	Electronic
Construction type	Built-in
Main colour of product	White
Electrical connection rating (W)	140
Current (A)	16
Voltage (V)	220-240
Frequency (Hz)	50
Number of compressors	1
Length of Electrical Supply Cord (cm)	245
Plug type	Schuko
Total unit net capacity (l)	400
Star Rating	4
Height of the product	1935
Width of the product	690
Depth of the product	545
Maximum adjustability feet	0
Net weight (kg)	74

## TECHNICAL FEATURES

Defrost process fridge section	Automatic
Defrost process freezer section	Manual
Fast cooling possibility	Yes
Fast freezing function	Yes
Door opened indicator freezer	No
Temperature adjustable	Yes
Temperature adjustable freezer	No
Interior ventilator fridge section	Yes
Number of freezing drawers	3
Automatic motor-driven ice-maker	N/A
Number of shelves in fridge compartment	5
Material of the shelves	Glass
Thermometer fridge section	None
Thermometer freezer section	None
Number of temperature zones	2

## PERFORMANCES

Energy efficiency class - NEW (2010/30/EU)	A+
Energy consumption annual (kWh/annum) - NEW (2010/30/EU)	328
Refrigerator Net capacity (l) - NEW (2010/30/EU)	299
Freezer Net capacity (l) - NEW (2010/30/EU)	101
Freezing capacity (kg/24h) - NEW (2010/30/EU)	4.5
Climate class	SN-T
Noise level (dB(A) re 1 pW)	35
Frost free system	No

