

AKT 8090/NE

12NC: 859408001000

EAN code: 8003437829543

Whirlpool

SENSING THE DIFFERENCE

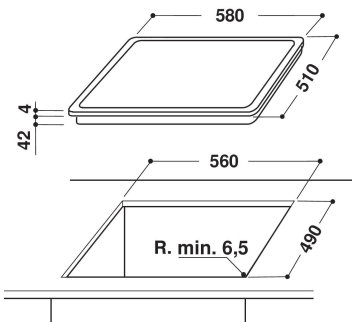
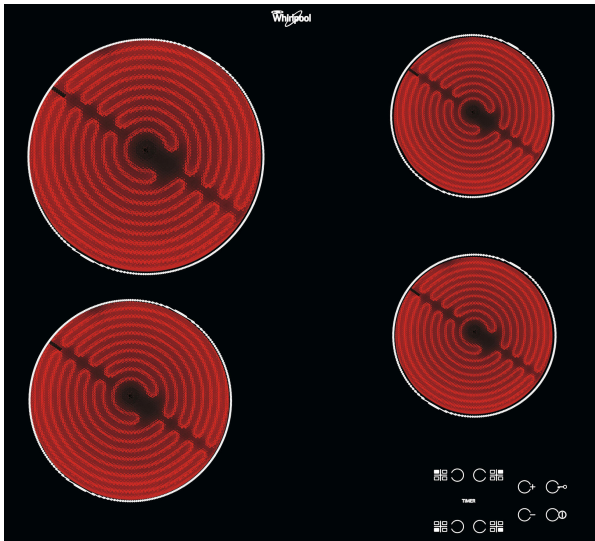

MAIN FEATURES

Product group	Hob
Construction type	Built-in
Type of control	Electronic
Type of control setting and signalling devices	-
Number of gas burners	0
Number of electric cooking zones	4
Number of electric plates	0
Number of radiant plates	4
Number of halogen plates	0
Number of induction plates	0
Number of electric warming zones	0
Location of control panel	Hob Front
Basic surface material	Glass
Main colour of product	Black
Electrical connection rating (W)	6200
Gas connection rating (W)	0
Current (A)	27,8
Voltage (V)	220-240
Frequency (Hz)	50
Length of Electrical Supply Cord (cm)	0
Plug type	No
Gas connection	N/A
Width of the product	580
Height of the product	46
Depth of the product	510
Minimum niche height	42
Minimum niche width	560
Niche depth	490
Net weight (kg)	8
Automatic programmes	No

TECHNICAL FEATURES

Power on indicator	Yes
Plate on indicator	4
Type of regulation	Radiant
Type of lid	Without
Residual heat indicator	separate
Main on/off switch	Yes
Safety device	-
Timer	Switch-off

PERFORMANCES

Energy input	Electric
--------------	----------