

# W7I HF60 TUS UK

12NC: 859991657770

GTIN (EAN) code: 8003437639845

Whirlpool

SENSING THE DIFFERENCE

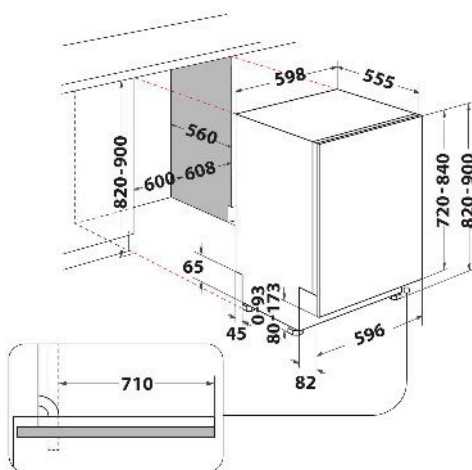

- Installation Type: Built-in
- Energy class A+++
- 15 place settings
- 6TH Sense Technology
- Noise level: 41 dB(A)
- 9.5 L per cycle (2660 L per year)
- PowerCleanPro
- PowerCleanPRO
- Third rack: Yes, flexible + handle inox
- Autoclean filter
- Start delay 1-24 h
- FlexiSpace
- Adjustable upper rack
- Sliding hinges for plinth up to 0 cm
- Half load
- Prewash
- Express

## Whirlpool integrated dishwasher: black color, full size - W7I HF60 TUS UK

This Whirlpool integrated Dishwasher features: black color. Outstanding A+++ energy rating, for reduced energy consumption. Innovative technology ensuring extra silent performance, for a very quiet appliance. Superb cleaning performance, for ideal washing results. Outstanding drying performance, providing excellent results.

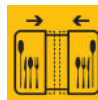

### Flex Third Rack

The third rack is perfect for accommodating cutlery and utensils and is equipped with sliding modules that allows you to easily load higher items on the middle rack.



### NaturalDry

The automatic door opening at the end of the program ensures better and more natural drying. This system guarantees higher energy efficiency and better drying results.



### Silent Option

A specific option that reduces the noise level up to 3dB(A) while reaching perfect washing and drying performance.



### MaxiSpace Tub

10% extra \*\* space that offers loading versatility and plenty of space for every item, for every occasion. \*Comparison between Whirlpool dishwasher models with standard tub and Whirlpool dishwasher models with MaxiSpace tub. Extra space refers to the increased total loading area among the three racks.



### Super Silent

Silent efficiency. This Whirlpool Dishwasher is designed to provide ideal results, while ensuring a silent noise output, so you can enjoy some extra peace and quiet.



### 6th Sense

No prewash required. technology provides perfect washing results with no pre-washing, soaking or scrubbing by hand, while effectively reducing water consumption and costs.



### A Energy Class

Unparalleled energy efficiency. This Whirlpool appliance features maximum energy savings at energy class A.



### New Railing System

Smoother movements of the lower rack due to a significant improvement in the quality and design, so the user can load heavy items without compromising the rack performance.



### Auto Mixed Cycle

Automatic cycle suitable for mixed loads, usually suitable for everyday use.

# W7I HF60 TUS UK

12NC: 859991657770

GTIN (EAN) code: 8003437639845

**Whirlpool**

SENSING THE DIFFERENCE

## MAIN FEATURES

|                                       |                  |
|---------------------------------------|------------------|
| Construction type                     | Built-in         |
| Installation type                     | Full-integrated  |
| Type of control                       | Electronic       |
| Type of control settings              | -                |
| Removable work top                    | No               |
| Door decor panel                      | N/A              |
| Main colour of product                | Black            |
| Electrical connection rating (W)      | 1900             |
| Current (A)                           | 13               |
| Voltage (V)                           | 220-240          |
| Frequency (Hz)                        | 50               |
| Length of Electrical Supply Cord (cm) | 130              |
| Plug type                             | UK               |
| Length inlet hose (cm)                | 155              |
| Length outlet hose (cm)               | 150              |
| Adjustable plinth                     | No               |
| Height of removable worktop (mm)      | 0                |
| Adjustable feet                       | Yes - front only |
| Height of the product                 | 820              |
| Width of the product                  | 598              |
| Depth of the product                  | 555              |
| Depth with open door 90 degree (mm)   | -                |
| Minimum niche height                  | 820              |
| Maximum niche height                  | 900              |
| Minimum niche width                   | 600              |
| Maximum niche width                   | 600              |
| Niche depth                           | 560              |
| Net weight (kg)                       | 35.5             |
| Gross weight (kg)                     | 37.5             |

## TECHNICAL FEATURES

|   |            |
|---|------------|
| Automatic programmes                      | Yes        |
| Maximum temperature for water intake (°C) | 60         |
| Start delay options                       | Continuous |
| Start delay time max. (h)                 | 24         |
| Progress indicator                        | -          |
| Digital countdown indicator               | Yes        |
| Salt light indicator                      | Yes        |
| Rinse aid light indicator                 | Yes        |
| Safety device                             | Yes        |
| Adjustable upper basket                   | Yes        |
| Largest loadable dish upper basket (cm)   | 0          |
| Largest loadable dish lower basket (cm)   | 0          |
| Number of place settings                  | 15         |

## PERFORMANCES

|  |      |
|--|------|
| Energy efficiency class - NEW (2010/30/EU)               | A+++ |
| Energy consumption annual (kWh/annum) - NEW (2010/30/EU) | 169  |
| Duration of the left-on mode - NEW (2010/30/EU)          | 12   |
| Power consumption in left-on mode - NEW (2010/30/EU)     | 6    |
| Power consumption in off-mode - NEW (2010/30/EU)         | 0.5  |
| Water consumption annual (l/annum) - NEW (2010/30/EU)    | 2660 |
| Noise level (dB(A) re 1 pW)                              | 41   |

**ENERG** Y IA  
енергия · ενεργεια IE IA

**WHIRLPOOL**  
W7I HF60 TUS UK

**A+++**

**169**  
kWh/annum

**2660**  
L/annum

**41**  
dB

**X 15**

2010/1059