

WCW707HTSBF

12NC: 859991693820

GTIN (EAN) code: 8003437397875

Whirlpool

SENSING THE DIFFERENCE

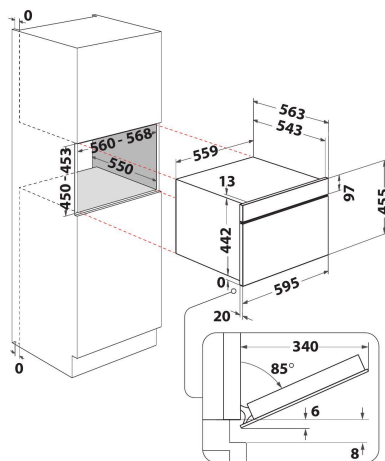

- 6TH Sense technology
- Crisp Function
- Cavity 52L
- Jet Start: rapid food reheating
- Jet Defrost: fast reheating
- ForcedAir
- Keep warm
- Steam function
- Rising Function
- CrispFry
- Bread Defrost function
- 950 W microwave
- Protruding handle
- Maximum dish diameter: 410 mm
- Full Touch Screen Control panel
- Drop down opening
- Crisp plate and handle

Whirlpool built in microwave oven: black color - WCW707HTSBF

This Whirlpool built in Microwave Oven features: black color. Outstanding cavity size. Combination technology, providing the cooking flexibility of traditional ovens. Crisp function, for unbeatably crisp quiches, pizzas and pies. Jet Defrost function for exceptionally fast and even defrosting.



Steam

Healthy, steamed meals, anytime. Steam technology provides the healthiest, tastiest recipes, at the touch of a button.



JetDefrost

Fast defrosting. Use the unique JetDefrost 3D system to defrost food effectively and with ease in your microwave oven.



Forced Air

Seal in the taste. Thanks to the Forced Air technology, preheated air is circulated inside your microwave oven using an innovative convection system, giving you moist, juicy cooking results.

Jet Start

Outstanding reheating speed. The JetStart function boosts the heat inside the oven to the maximum for 30 seconds, providing the ideal temperature to reheat food with high water content such as clear soups or beverages.



Softclosing Hinges

The new generation of hinges prevents any noisy slamming, so with just one gentle touch the doors effortlessly close smoothly and silently.



Child lock

Safety first. This Whirlpool Microwave features a child lock system, to prevent toddlers and children from accidentally using this appliance.



Crisp

Unbeatable crispness. This Whirlpool Microwave's Crisp function and dedicated pan ensures you can cook the crispiest pizza, pie or quiche, anytime.



CrispFry

To cooks delicious dishes with a fried texture and taste, but with little or no oil so it is even healthier to use than a frying pan.



DoughRising

Perfect yeast preparation for bread and dough with DoughRising Function. A special program to keep the Maxi Chef's internal temperature stable at 30°: ideal for dough to rise.

WCW707HTSBF

12NC: 859991693820

GTIN (EAN) code: 8003437397875

Whirlpool

SENSING THE DIFFERENCE

MAIN FEATURES

Product group	Microwave
Commercial code	WCW707HTSBF
Main colour of product	Black
Type of micro-wave oven	MW-Combi
Construction type	Built-in
Type of control	Electronic
Type of control settings	Touch-control
Additional cooking method Grill	Yes
Crisp	Yes
Steam	Yes
Additional cooking method Fan cooking	Yes
Clock	Yes
Automatic programmes	Yes
Height of the product	455
Width of the product	559
Depth of the product	543
Minimum niche height	450
Minimum niche width	560
Niche depth	550
Net weight (kg)	41
Cavity capacity (l)	53
Turntable	No
Turntable diameter (mm)	0
Integrated Cleaning system	Hydrolytic

TECHNICAL FEATURES

Current (A)	16
Voltage (V)	220-240
Frequency (Hz)	50
Length of electrical supply cord (cm)	150
Plug type	Schuko
Timer	Yes
Grill power (W)	2000
Type of grill	Heating element
-	Enamelled
Interior light	Yes
Additional cooking method Grill	Yes
Position of interior lights of the cavity	Right side
Maximum Air flow -	0
Minimum air flow -	0
Sound power at max. speed (2010/30/EU) -	0
Sound power at min. speed (2010/30/EU) -	0

PERFORMANCES

6th Sense / Dynamic Intelligence	Dynamic Intelligence
Number of power levels	7
Maximum micro-wave power (W)	950
Bread defrost	Yes
Jet defrost	Yes
Jet start	Yes
Energy efficiency class - NEW (2010/30/EU) -	x