

# BRABURA

## GRILLS



## KITCHEN LITE SERIES

INSTRUCTIONS MANUAL / MANUAL DE INSTRUCCIONES / BEDIENUNGSANLEITUNG / MANUEL D'INSTRUCTIONS / MANUALE DI ISTRUZIONI

CALLE ACERO 12 | 06220 VILAFRANCA DE LOS BARROS (BADAJOZ) | SPAIN

LS ED00 | [braburagrills.com](http://braburagrills.com)

## VALID FOR

VALIDO PARA / GÜLTIG FÜR / VALABLE POUR / VALIDO PER

---

**BRABURA**  
GRILLS

Model No: BKC0032  
**LITE SERIES 400**

Model No: BKC0033  
**LITE SERIES 300**

# CONTENTS

ÍNDICE / INHALTSVERZEICHNIS / CONTENUS / INDICE

**BRABURA**  
GRILLS

<b>Introduction</b>	<b>4</b>
Introducción / Einführung / Introduction / Introduzione	
<b>Product dimensions</b>	<b>5</b>
Dimensiones / Ausmaß / Dimensions / Dimensioni	
<b>Parts list</b>	<b>7</b>
Lista de piezas / Teileliste / Liste des pièces / Lista dei parti	
<b>Components list</b>	<b>11</b>
Lista de componentes / Komponentenliste / Liste des composants / Lista dei componenti	
<b>Instructions</b>	<b>13</b>
Instrucciones / Anweisungen / Instructions / Istruzioni	
<b>Gas Connections</b>	<b>56</b>
Conexiones de gas / Gasanschlüsse / Raccordements de gaz / Collegamenti del gas	
<b>Adjustment</b>	<b>58</b>
Regulación / Anpassung / Ajustement / Regolazione	
<b>Cleaning and maintenance</b>	<b>59</b>
Limpieza y mantenimiento / Reinigung und Wartung / Nettoyage et entretien / Pulizia e manutenzione	
<b>Warranty</b>	<b>64</b>
Garantía / Garantie / Garantie / Garanzia	

# INTRODUCTION

ISTRUCCIONES / ANWEISUNGEN / INSTRUCTIONS / ISTRUZIONI

**BRABURA**  
GRILLS

## Welcome to your Lite Series Outdoor Kitchen

- EN Save these instructions.**
- Read these instructions completely and carefully. Do not skip any step. Put all bolts used in a step before tighten them.
  - Some parts have sharp edges, care must be taken to avoid injury. Please wear gloves when handling.
  - Two or more people should work together to assemble the outdoor kitchens and BRABURA Appliances.
  - During assembly, work on a protected surface to avoid damaging the pieces.
- ES Conserve estas instrucciones.**
- Lea estas instrucciones completamente y con cuidado. No omita ningún paso. Coloque todos los tornillos utilizados en un paso antes de apretarlos.
  - Algunas piezas tienen bordes afilados, tenga cuidado para evitar lesiones. Por favor, use guantes.
  - Se necesitan dos o más personas para colocar los electrodomésticos BRABURA en su lugar correspondiente
  - Durante el montaje, trabaje en una superficie protegida para no dañar las piezas.
- DE Bewahren Sie diese Anweisungen auf.**
- Lesen Sie diese Anweisungen vollständig und sorgfältig durch. Überspringen Sie keinen Schritt. Legen Sie alle verwendeten Schrauben in einem Schritt ab, bevor Sie sie festziehen
  - Einige Teile haben scharfe Kanten, seien Sie vorsichtig, um Verletzungen zu vermeiden. Bitte tragen Sie Handschuhe.
  - Zwei oder mehr Personen sollten zusammenarbeiten, um die BRABURA Haushaltsgeräte in das entsprechende Modul einzusetzen.
  - Während des Zusammenbaus auf einer geschützten Oberfläche arbeiten, um Beschädigungen der Teile zu vermeiden.
- FR Conservez ces instructions.**
- Lisez attentivement ces instructions. Ne sautez aucune étape. Placez toutes les vis utilisées à une étape avant de les serrer.
  - Certaines pièces ont des bords tranchants, soyez prudent pour éviter les blessures. Veuillez utiliser des gants.
  - Deux personnes ou plus doivent travailler ensemble pour installer les appareils électroménagers BRABURA dans leur module correspondant.
  - Pendant l'assemblage, travaillez sur une surface protégée pour éviter d'endommager les pièces.
- IT Conservare queste istruzioni.**
- Leggere attentamente e completamente queste istruzioni. Non tralasciare alcun passo. Colocare tutte le viti utilizzate in un passaggio prima di stringerle.
  - Alcune parti potrebbero avere bordi taglienti, fare attenzione per evitare lesioni. Si prega di utilizzare i guanti.
  - Sono necessarie due o più persone per posizionare gli elettrodomestici BRABURA nei rispettivi moduli.
  - Durante l'assemblaggio, lavorare su una superficie protetta per evitare danni alle parti.

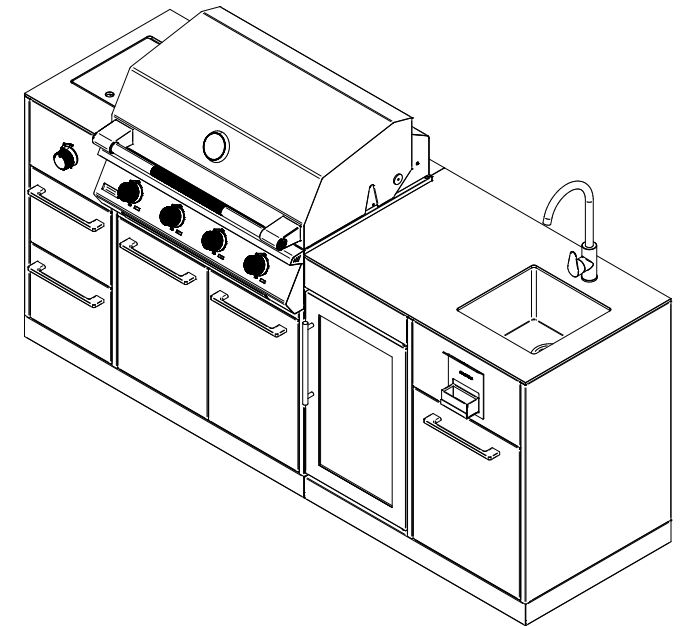

# PRODUCT DIMENSIONS

DIMENSIONES / AUSMASS / DIMENSIONS/ DIMENSIONI

# BRABURA

GRILLS

## Lite Series 400

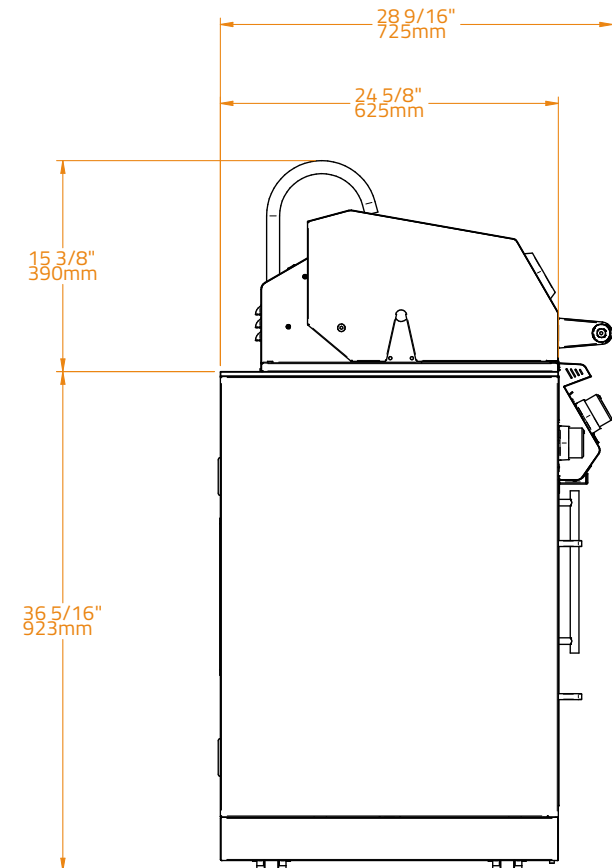
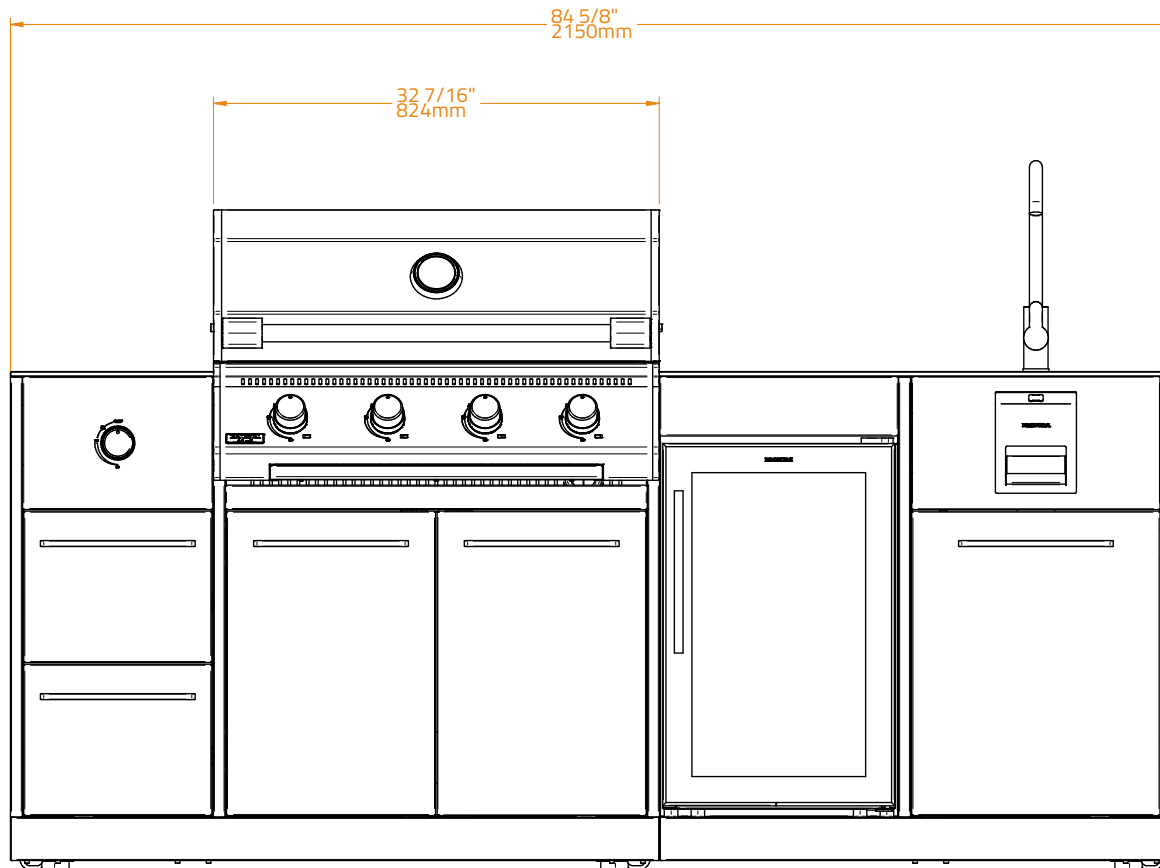

# PRODUCT DIMENSIONS

DIMENSIONES / AUSMASS / DIMENSIONS/ DIMENSIONI

# BRABURA

GRILLS

## Lite Series 300

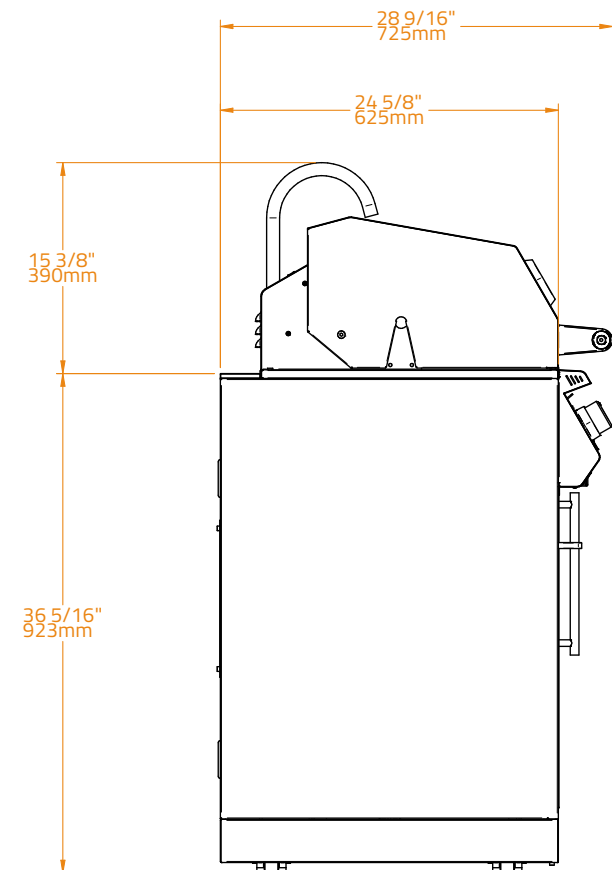
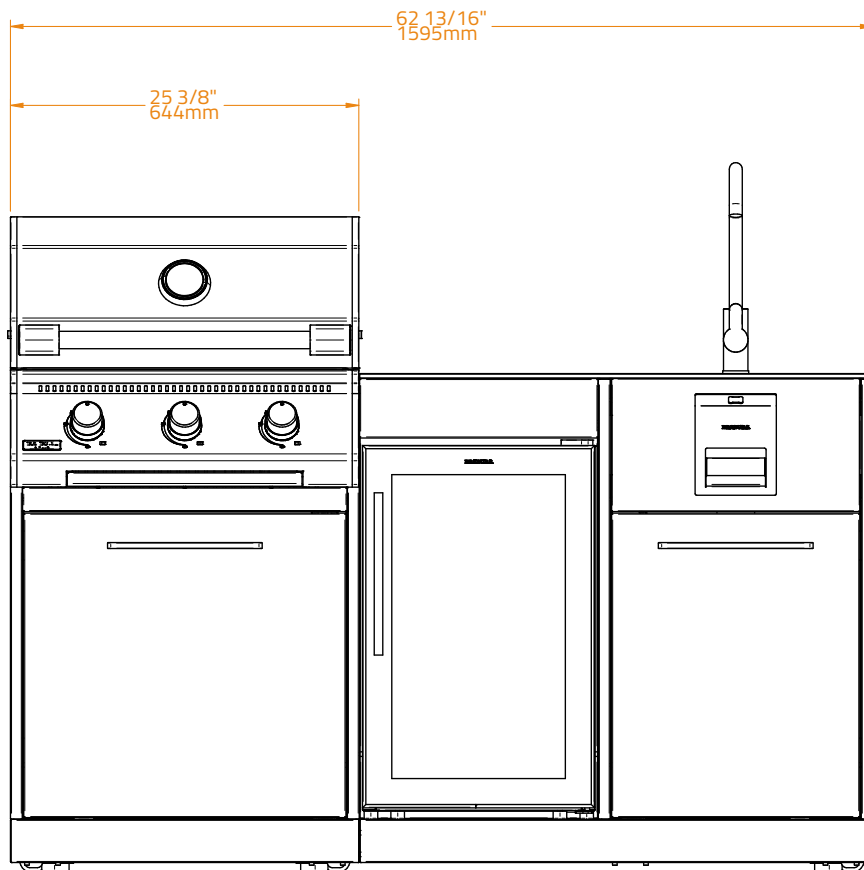

# PARTS LIST

LISTA DE PIEZAS / TEILELISTE / LISTE DES PIÈCES / LISTA DEI PARTI

# BRABURA

GRILLS

## LITE Series 400

ITEM	NAME/NOMBRE/NAME/NOM/NOME	QTY
1	L-BASE	1
2	R-BASE	1
3	FLANK N1	1
4	FLANK N2	1
5	FLANK N3	1
6	FLANK N4	1
7	FLANK N5	1
8	BURNER REAR	1
9	GRILL REAR	1
10	FRIDGE REAR	1
11	SINK REAR	1
12	BURNER	1
13	L-DOOR	1
14	R-DOOR	1
15	BIN DOOR	1
16	REGISTER TOP	1

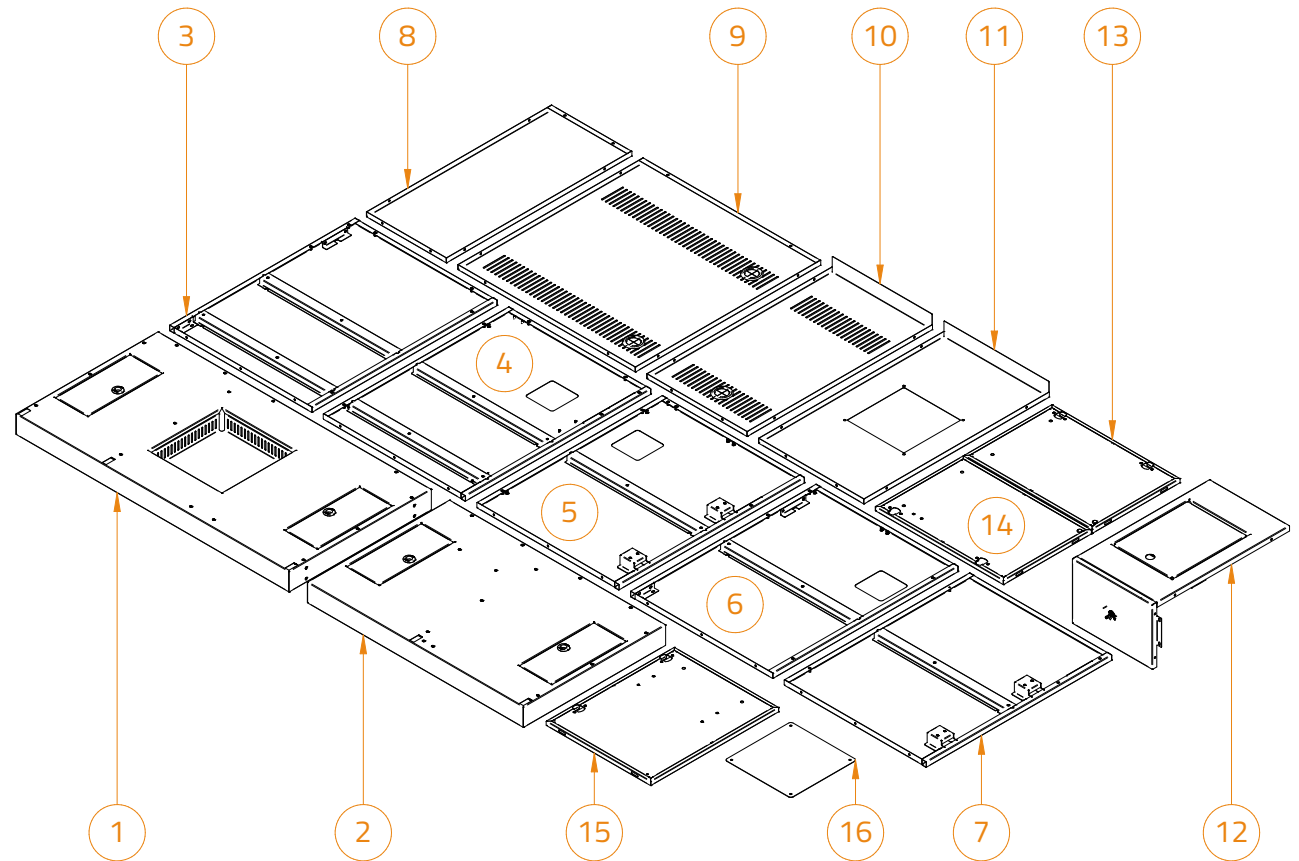

# PARTS LIST

LISTA DE PIEZAS / TEILELISTE / LISTE DES PIÈCES / LISTA DEI PARTI

# BRABURA

GRILLS

## LITE Series 400

ITEM	NAME/NOMBRE/NAME/NOM/NOME	QTY
17	GRILL RIB	1
18	GRILL STONE SUPPORT	1
19	FRIDGE STONE SUPPORT	1
20	FRIDGE RIB	1
21	SINK RIB	1
22	DRAWER DOOR	2
23	DRAWER	2
24	BIN FRAME	1
25	FRIDGE PLACE POSITIONER	1
26	GRILL DOOR STOPPER	1
27	BIN DOOR STOPPER	1
28	BOTTLE OPENER	1
29	CAP BOX	1
30	SINK STONE	1
31	BURNER FRAME STONE	1
32	BURNER TOP STONE	1
33	GRILL STONE	1
34	L-BRACKET TUBE	2
35	R-BRACKET TUBE	3
36	SINK	1

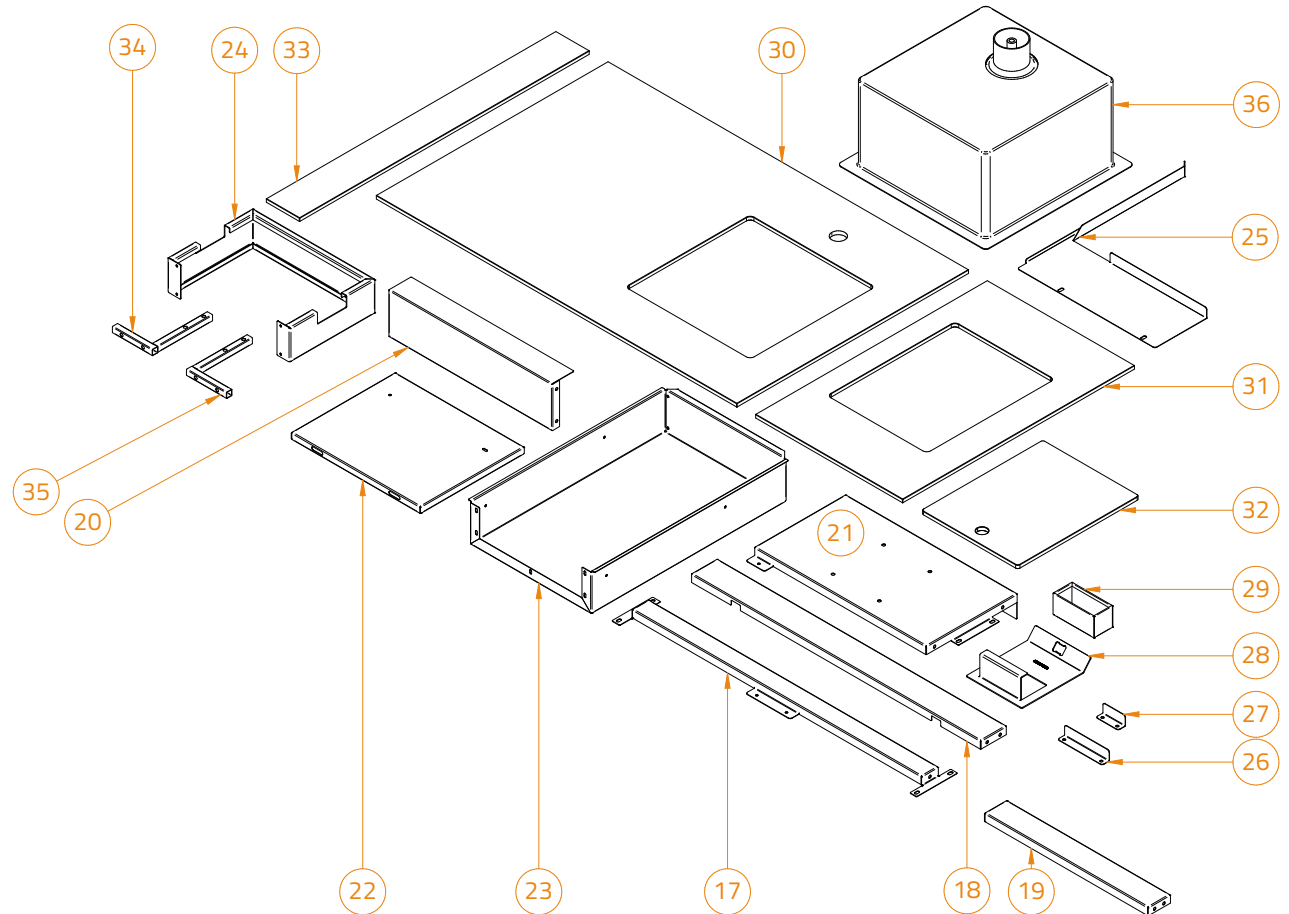

# PARTS LIST

LISTA DE PIEZAS / TEILELISTE / LISTE DES PIÈCES / LISTA DEI PARTI

# BRABURA

GRILLS

LITE Series 300

ITEM	NAME/NOMBRE/NAME/NOM/NOME	QTY
1	L-BASE	1
2	R-BASE	1
3	FLANK N6	1
4	FLANK N3	1
5	FLANK N4	1
6	FLANK N5	1
7	GRILL REAR	1
8	FRIDGE REAR	1
9	SINK REAR	1
10	DOOR	1
11	BIN DOOR	1
12	REGISTER TOP	1

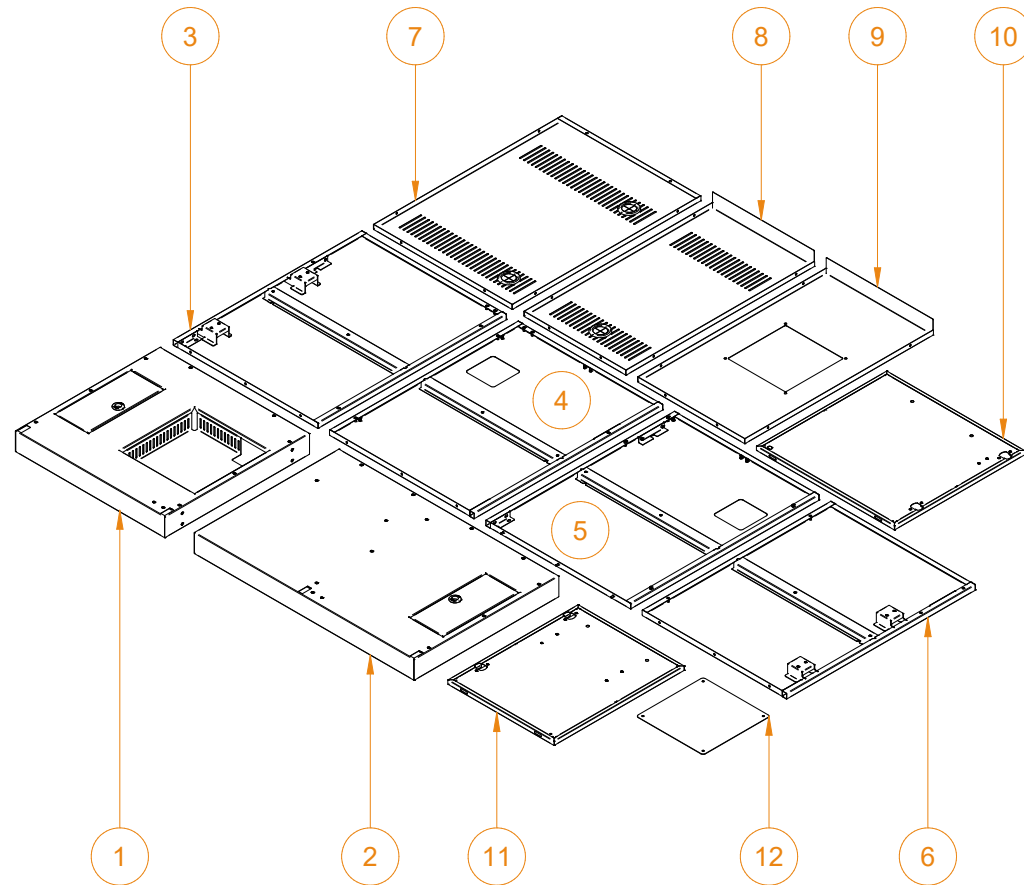

# PARTS LIST

LISTA DE PIEZAS / TEILELISTE / LISTE DES PIÈCES / LISTA DEI PARTI

# BRABURA

GRILLS

## LITE Series 300

ITEM	NAME/NOMBRE/NAME/NOM/NOME	QTY
13	GRILL RIB	1
14	GRILL STONE SUPPORT	1
15	FRIDGE RIB	1
16	FRIDGE STONE SUPPORT	1
17	SINK RIB	1
18	BIN FRAME	1
19	FRIDGE PLACE POSITIONER	1
20	GRILL DOOR STOPPER	1
21	BIN DOOR STOPPER	1
22	BOTTLE OPENER	1
23	CAP BOX	1
24	GRILL STONE	1
25	SINK STONE	1
26	L-BRACKET TUBE	2
27	R-BRACKET TUBE	2
28	SINK	1

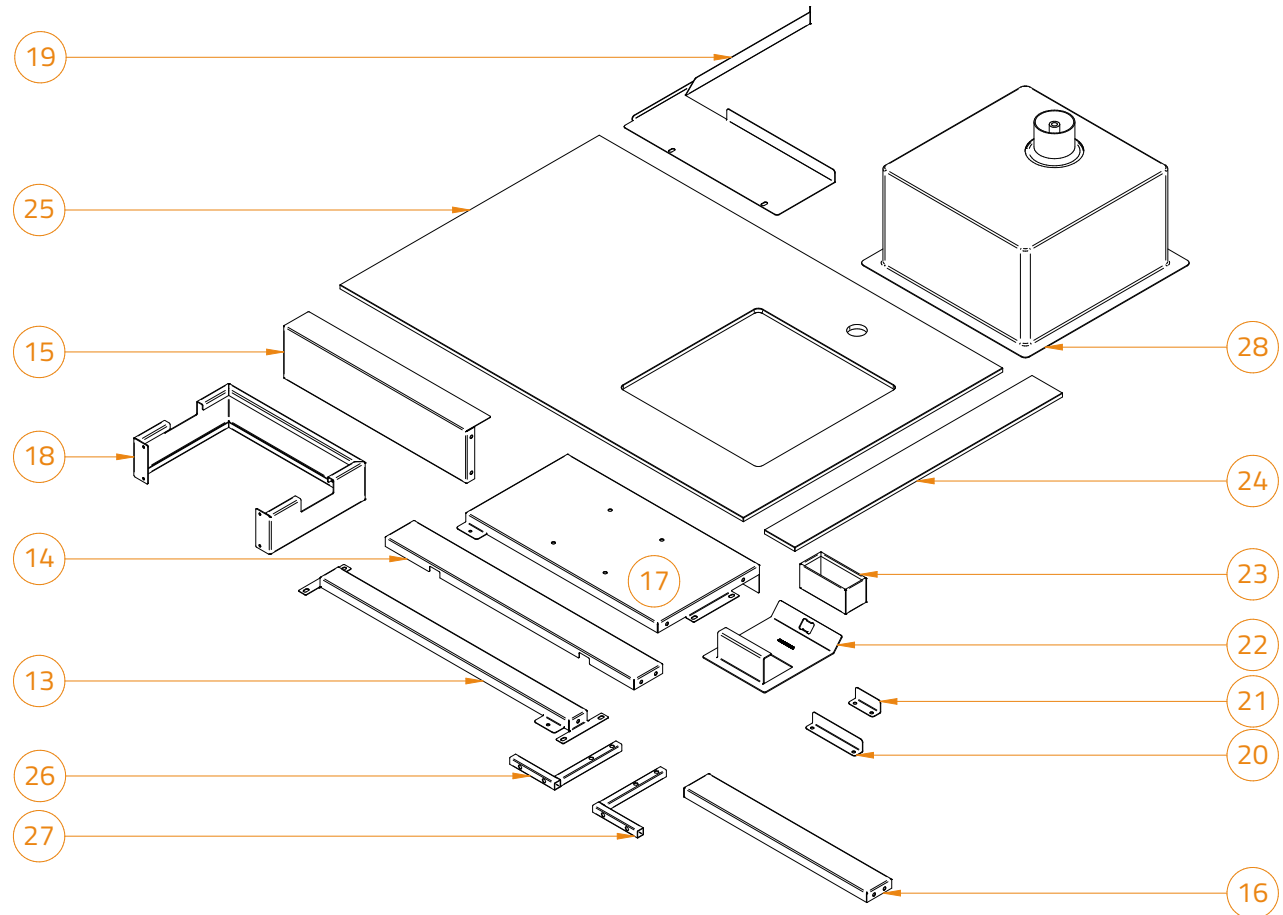

# COMPONENTS LIST

COMPONENTES / KOMPONENTEN / COMPOSANTS / COMPONENTI

# BRABURA

GRILLS

## LITE Series 400

ITEM	NAME/NOMBRE/NAME/NOM/NOME	QTY
1	WHEEL-MOUNTED LEG	8
2	PAPER-TOWEL SUPPORT	1
3	DRAWERS GUIDE	4
4	HANDLE	5
5	HINGE	6
6	KNOB	1
7	BEZEL	1
8	M4 NUT	15
9	FLATHEAD SCREW M4x10	16
10	ROUNDHEAD SCREW M4x10	16
11	COUNTERSUNK SCREW M4x10	3
12	COUNTERSUNK SCREW M4x16	24
13	SCREW M5x10	113
14	SCREW M6x20	32
15	ROUNDHEAD SCREW 8x16 M4x7	10
16	MAGNET	3
17	FAUCET	1
18	FAUCET HOSE	2
19	FAUCET SCREW ADAPTER	1
20	FAUCET LOWER CLAMP	1
21	T HOSE CONNECTION	1
22	BLACK WASHER	1
23	WHITE WASHER	1
24	ROUND RUBBER WASHER	1
25	Y GAS HOSE CONNECTION	1
26	GAS HOSE	2

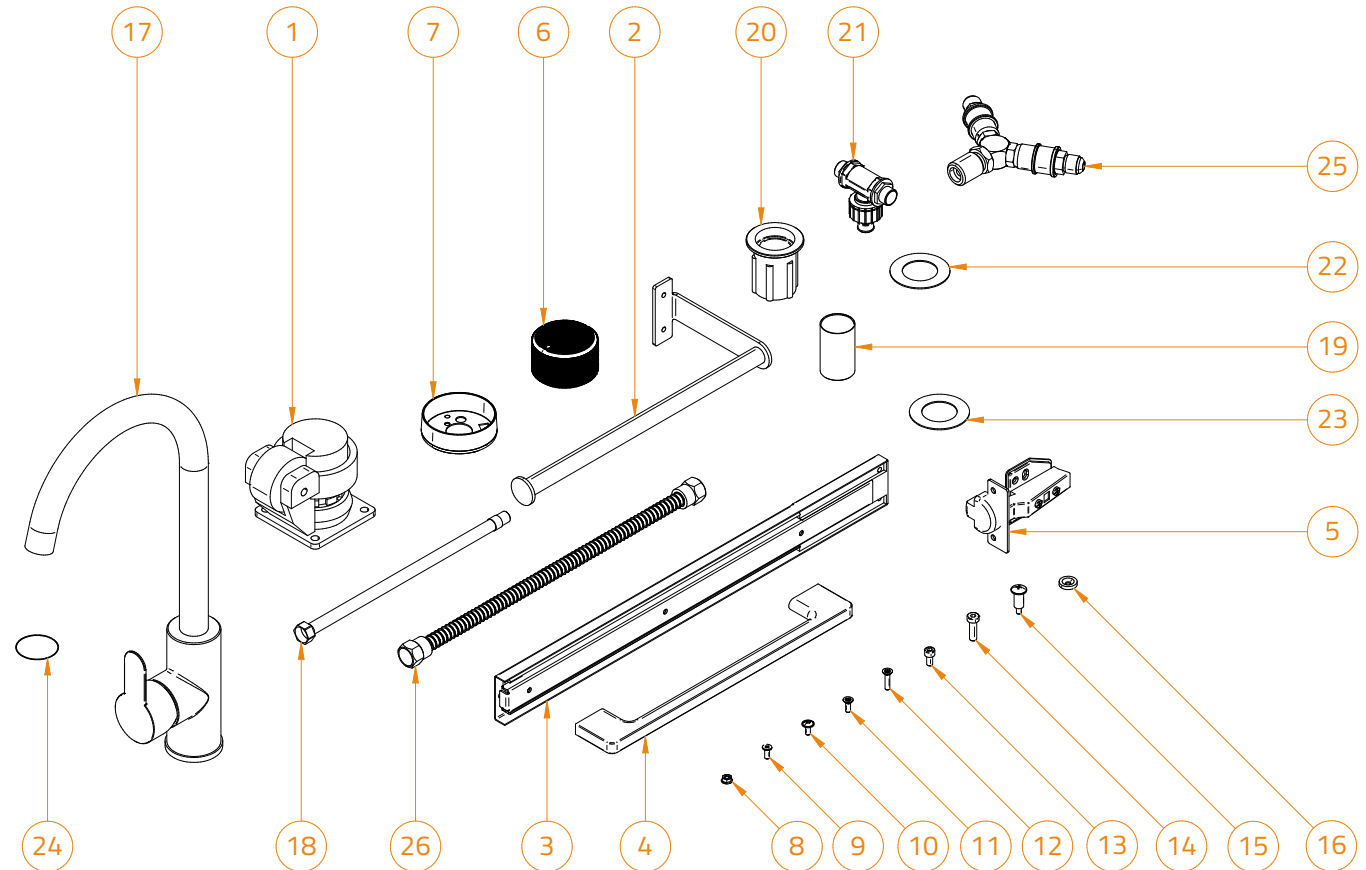

# COMPONENTS LIST

COMPONENTES / KOMPONENTEN / COMPOSANTS / COMPONENTI

# BRABURA

GRILLS

## LITE Series 300

ITEM	NAME/NOMBRE/NAME/NOM/NOME	QTY
1	WHEEL-MOUNTED LEG	6
2	PAPER-TOWEL SUPPORT	1
3	HANDLE	2
4	HINGE	4
5	M4 NUT	6
6	ROUNDHEAD SCREW M4x10	6
7	COUNTERSUNK SCREW M4x10	2
8	COUNTERSUNK SCREW M4x16	16
9	SCREW M5x10	86
10	SCREW M6x20	24
11	ROUNDHEAD SCREW 8x16 M4X7	4
12	MAGNET	2
13	FAUCET	1
14	FAUCET HOSE	2
15	FAUCET SCREW ADAPTER	1
16	FAUCET LOWER CLAMP	1
17	T HOSE CONNECTION	1
18	BLACK WASHER	1
19	WHITE WASHER	1
20	ROUND RUBBER WASHER	1

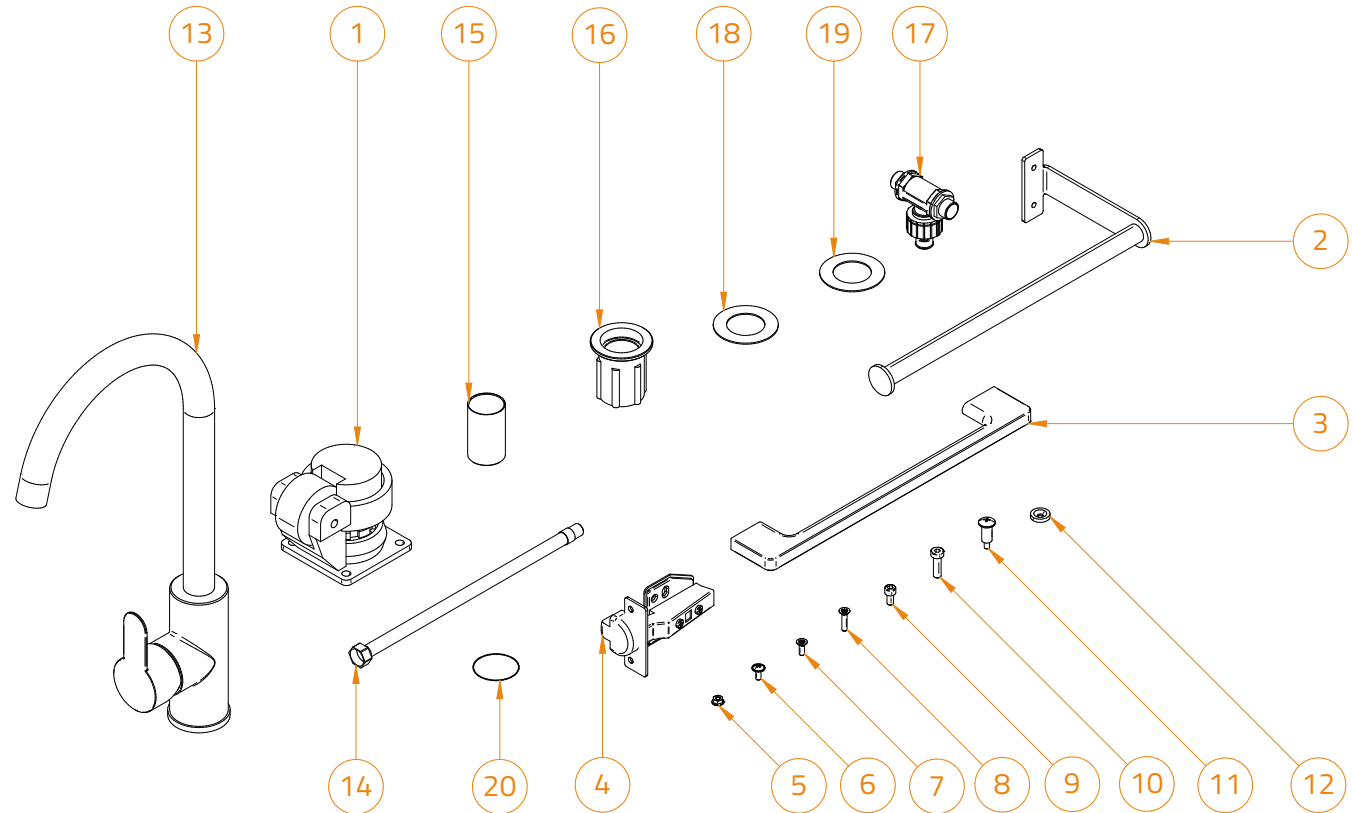

# INSTRUCTIONS

INSTRUCCIONES / ANWEISUNGEN / INSTRUCTIONS / ISTRUZIONI

# BRABURA

GRILLS

00

Step  
Paso  
Schritt  
Étape  
Passo

Before mounting LITE Series 400 & 500  
Register Doors + Bases

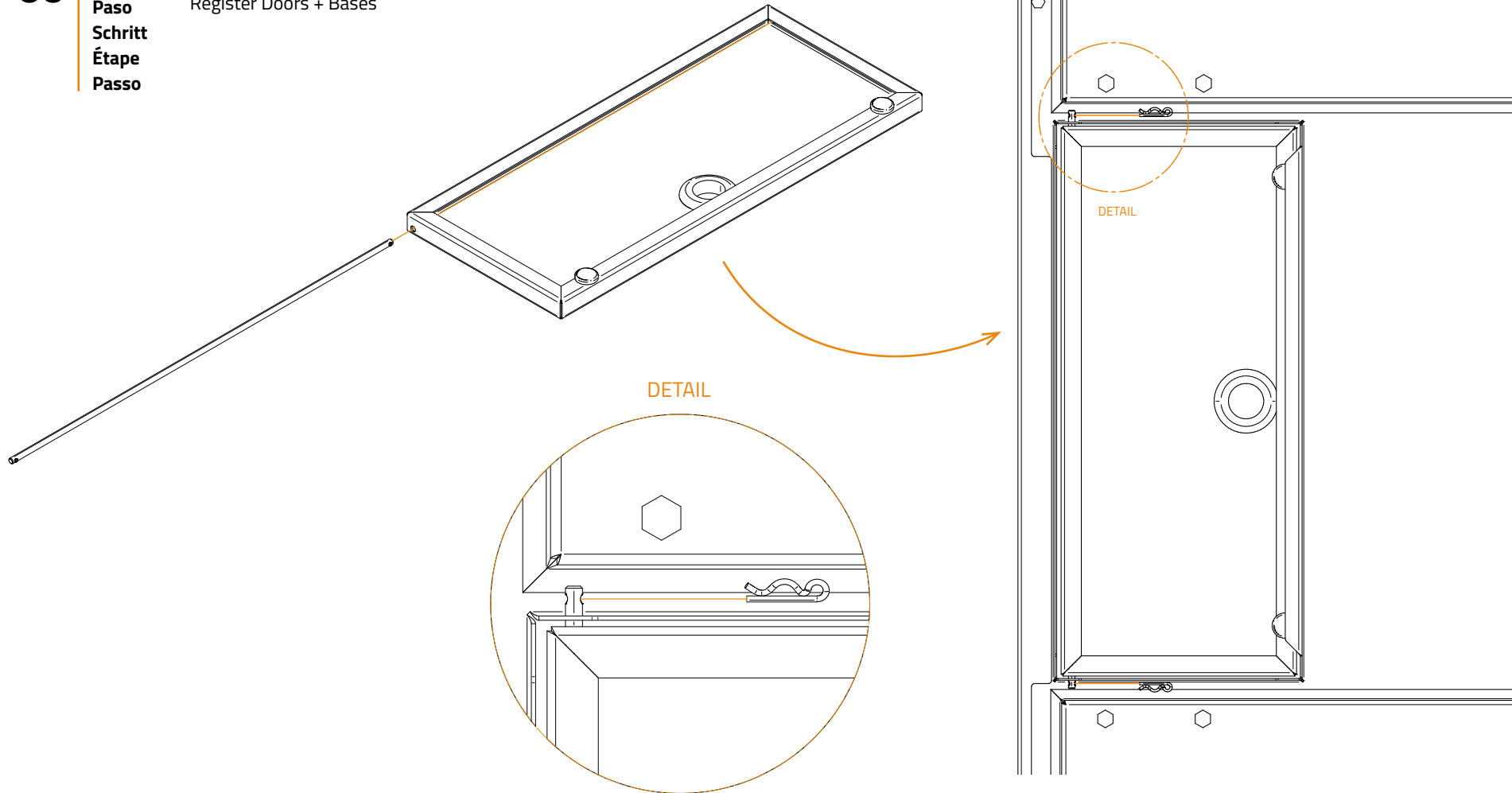

# INSTRUCTIONS

INSTRUCCIONES / ANWEISUNGEN / INSTRUCTIONS / ISTRUZIONI

# BRABURA

GRILLS

00

Step  
Paso  
Schritt  
Étape  
Passo

Before mounting LITE Series 400 & 500  
Gas Tank Bin + L-Base

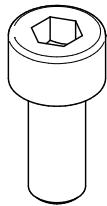

COMPONENT	QUANTITY
SCREW M5x10	4

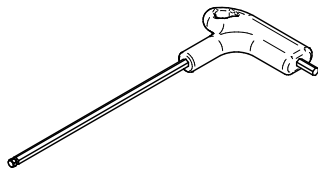

TOOLS REQUIRED
ALLEN WRENCH

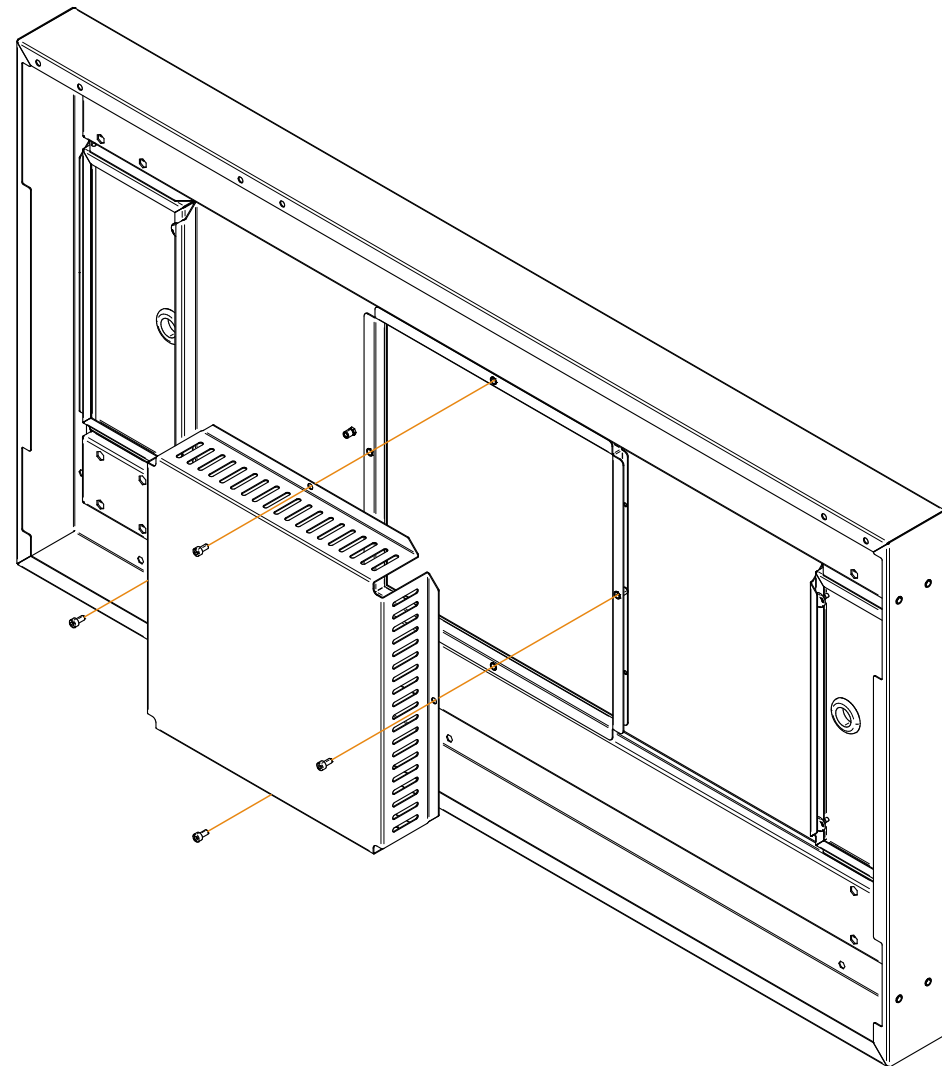

# INSTRUCTIONS

INSTRUCCIONES / ANWEISUNGEN / INSTRUCTIONS / ISTRUZIONI

# BRABURA

GRILLS

## 01

Step  
Paso  
Schritt  
Étape  
Passo

**LITE Series 400**  
Wheel-Mounted Leg (4) + L-Base  
Grill Door Stopper + L-Base

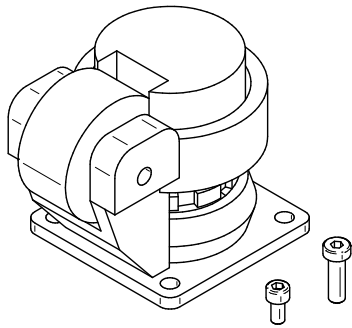

COMPONENTS	QUANTITY
WHEEL-MOUNTED LEG	4
SCREW M6x20	16
SCREW M5x10	2

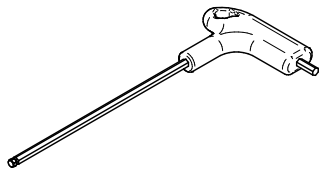

TOOLS REQUIRED

ALLEN WRENCH

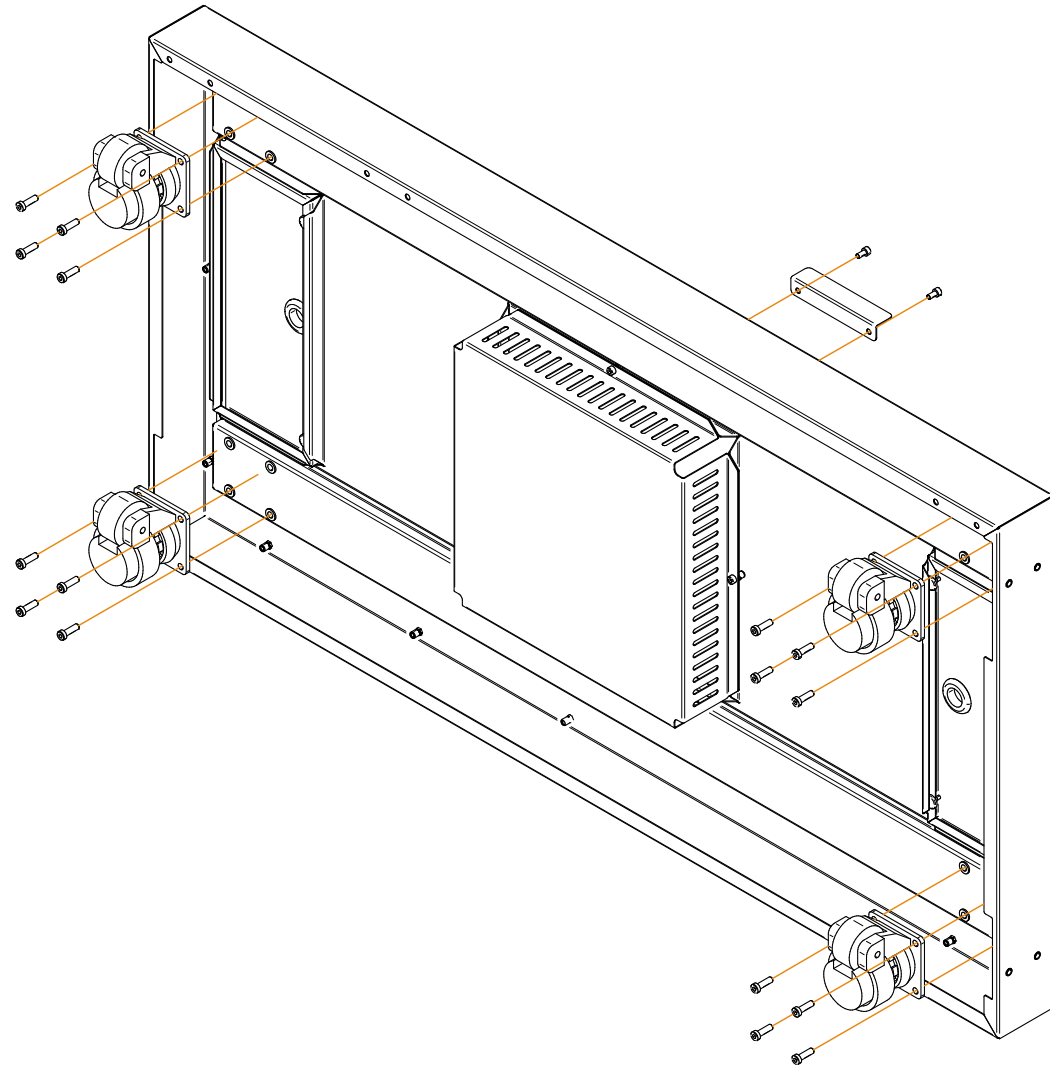

# INSTRUCTIONS

INSTRUCCIONES / ANWEISUNGEN / INSTRUCTIONS / ISTRUZIONI

# BRABURA

GRILLS

**02**

Step  
Paso  
Schritt  
Étape  
Passo

LITE Series 400  
L-Base + R-Base

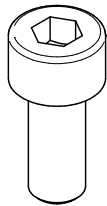

COMPONENT	QUANTITY
SCREW M5x10	4

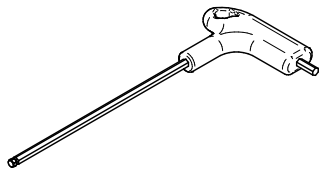

TOOLS REQUIRED
ALLEN WRENCH

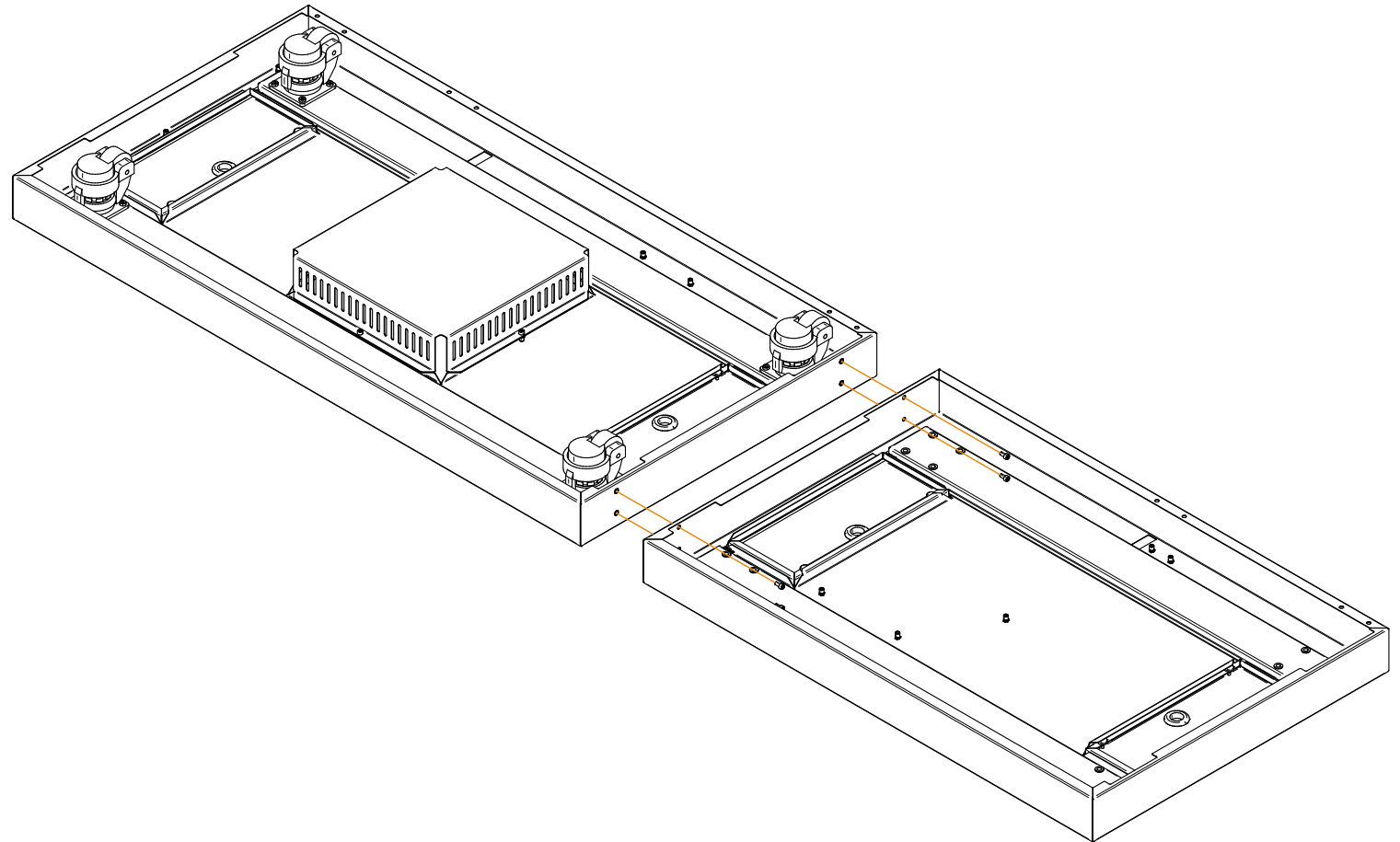

# INSTRUCTIONS

INSTRUCCIONES / ANWEISUNGEN / INSTRUCTIONS / ISTRUZIONI

# BRABURA

GRILLS

## 03

**Step** LITE Series 400  
**Paso** Wheel-Mounted Leg (4 ) + R-Base  
**Schritt** Bin Door Stopper + R-Base  
**Étape**  
**Passo**

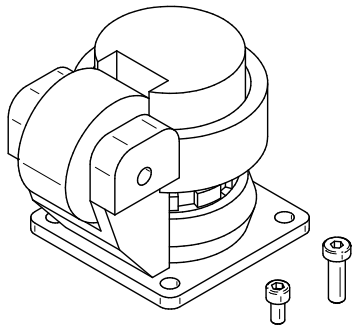

COMPONENTS	QUANTITY
WHEEL-MOUNTED LEG	4
SCREW M6x20	16
SCREW M5x10	2

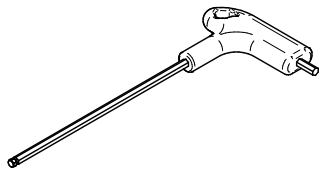

TOOLS REQUIRED
ALLEN WRENCH

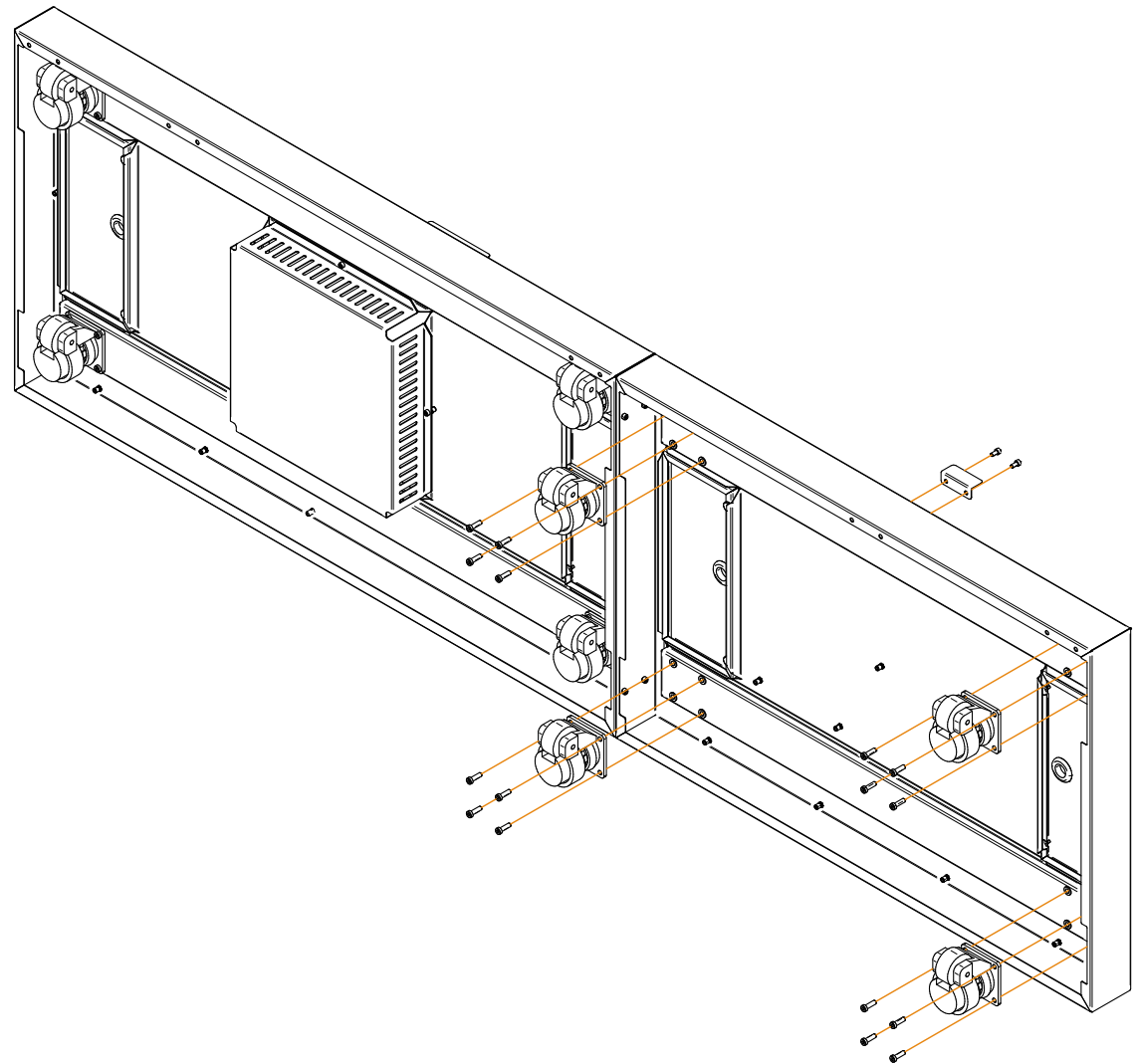

# INSTRUCTIONS

INSTRUCCIONES / ANWEISUNGEN / INSTRUCTIONS / ISTRUZIONI

# BRABURA

GRILLS

**04**

Step  
Paso  
Schritt  
Étape  
Passo

## LITE Series 400

L-Bracket Tube (1) + L-Base  
R-Bracket Tube (2) + L-Base  
L-Bracket Tube (1) + R-Base  
R-Bracket Tube (1) + R-Base

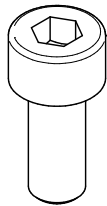

COMPONENT	QUANTITY
SCREW M5x10	10

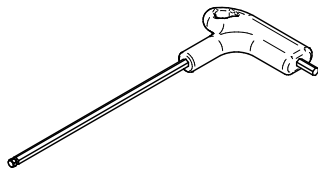

TOOLS REQUIRED
ALLEN WRENCH

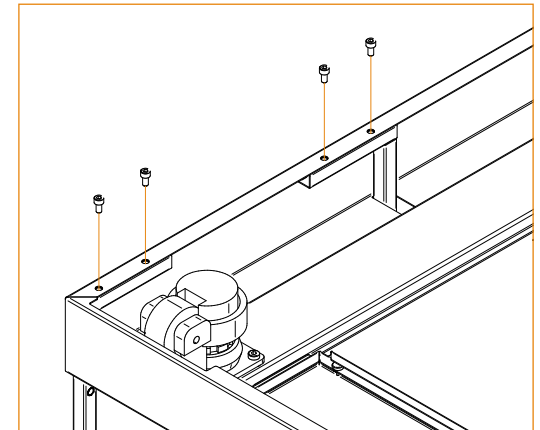
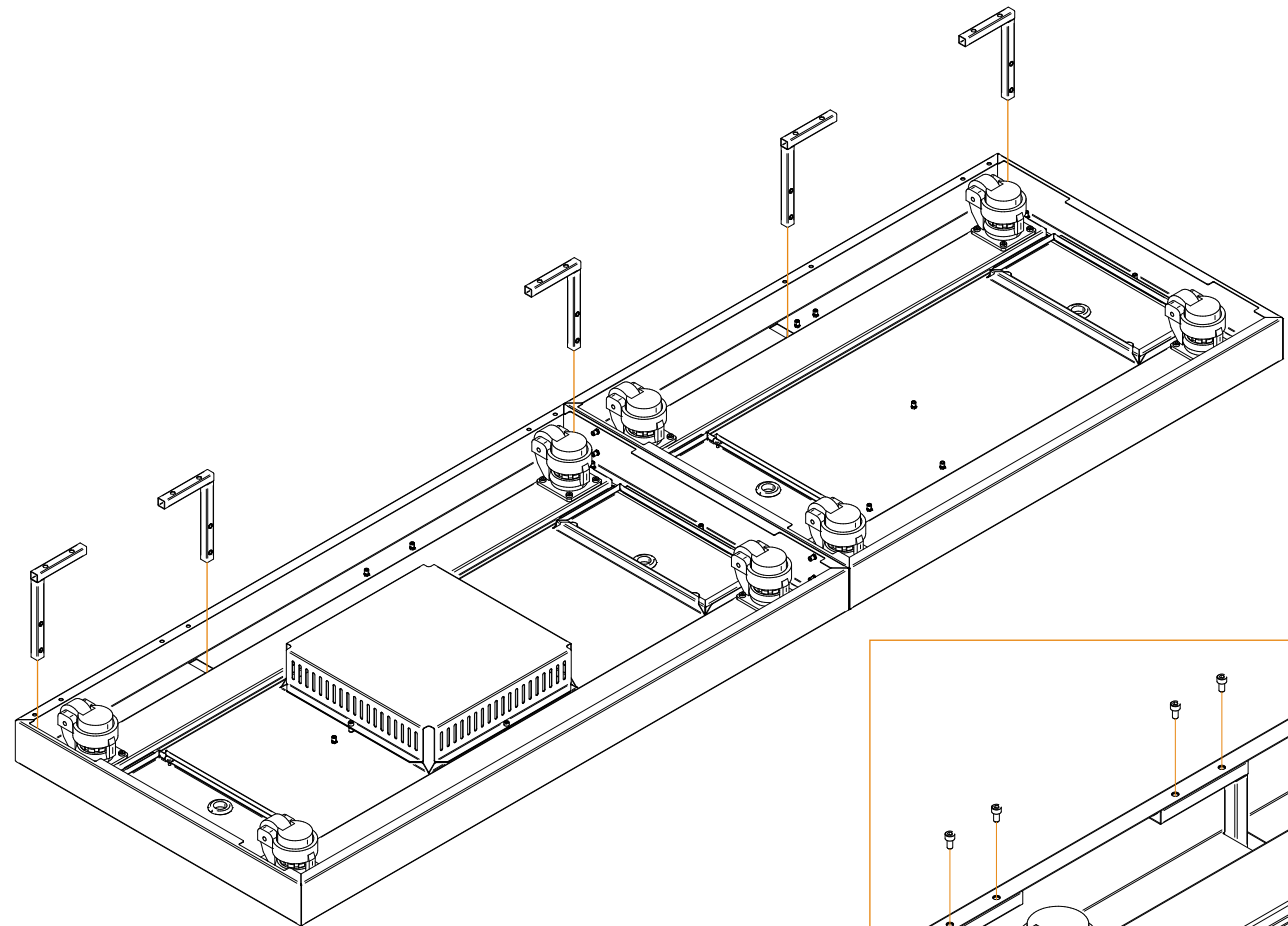

# INSTRUCTIONS

INSTRUCCIONES / ANWEISUNGEN / INSTRUCTIONS / ISTRUZIONI

# BRABURA

GRILLS

**05**

Step  
Paso  
Schritt  
Étape  
Passo

LITE Series 400  
Flank N1 + L-Base

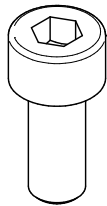

COMPONENT	QUANTITY
SCREW M5x10	5

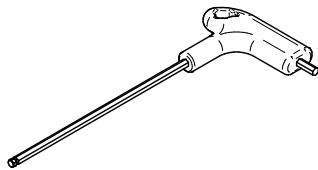

TOOLS REQUIRED
ALLEN WRENCH

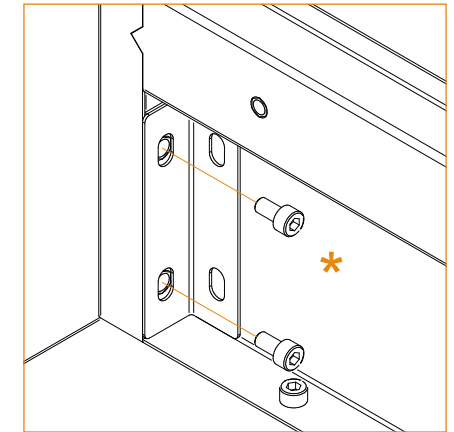
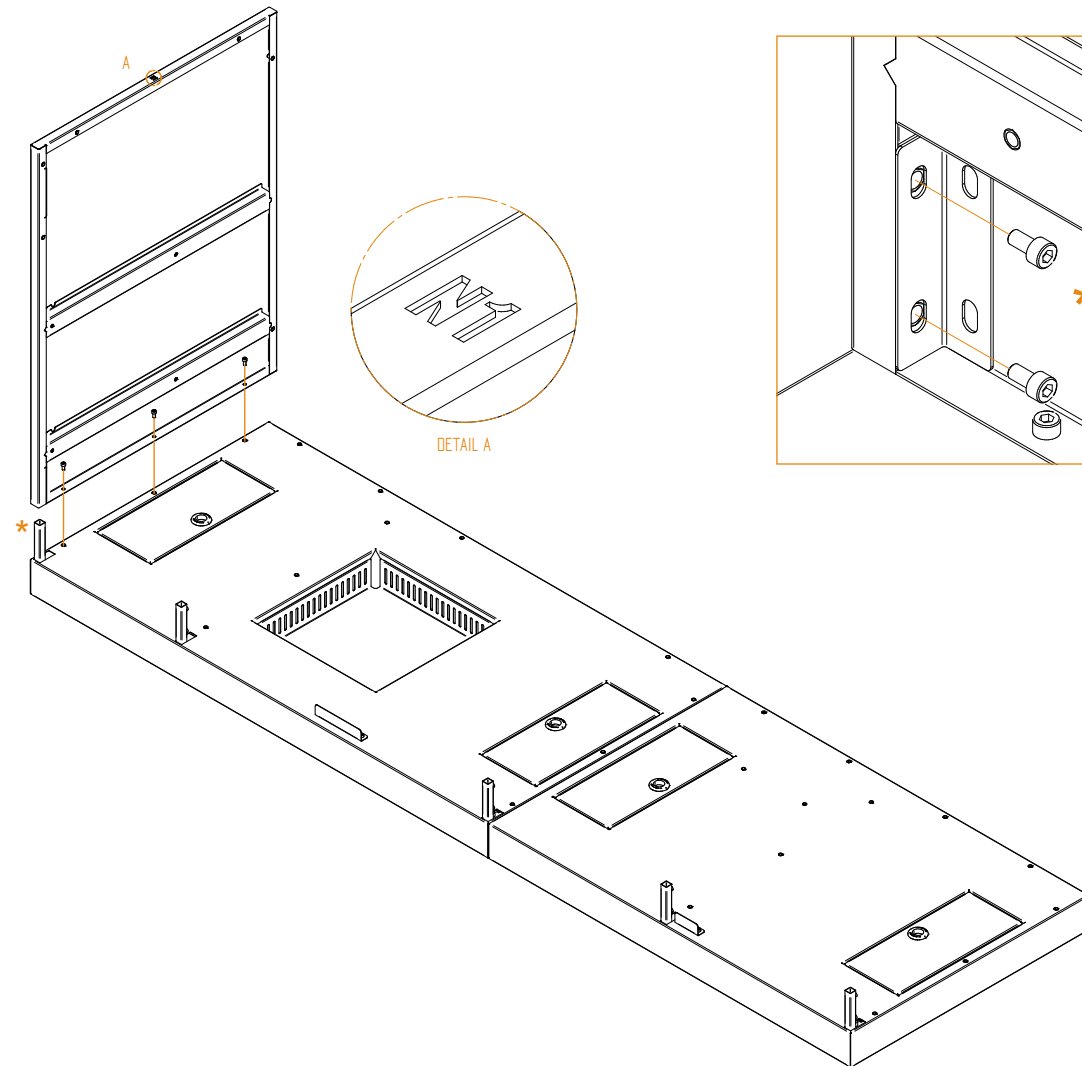

# INSTRUCTIONS

INSTRUCCIONES / ANWEISUNGEN / INSTRUCTIONS / ISTRUZIONI

# BRABURA

GRILLS

**06**

**Step** LITE Series 400  
**Paso** Burner Rear + L-Base  
**Schritt** Burner Rear + Flank N1  
**Étape**  
**Passo**

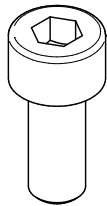

COMPONENT	QUANTITY
SCREW M5x10	4

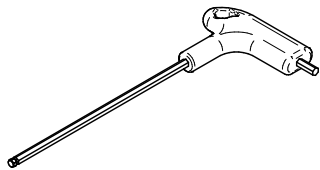

TOOLS REQUIRED
ALLEN WRENCH

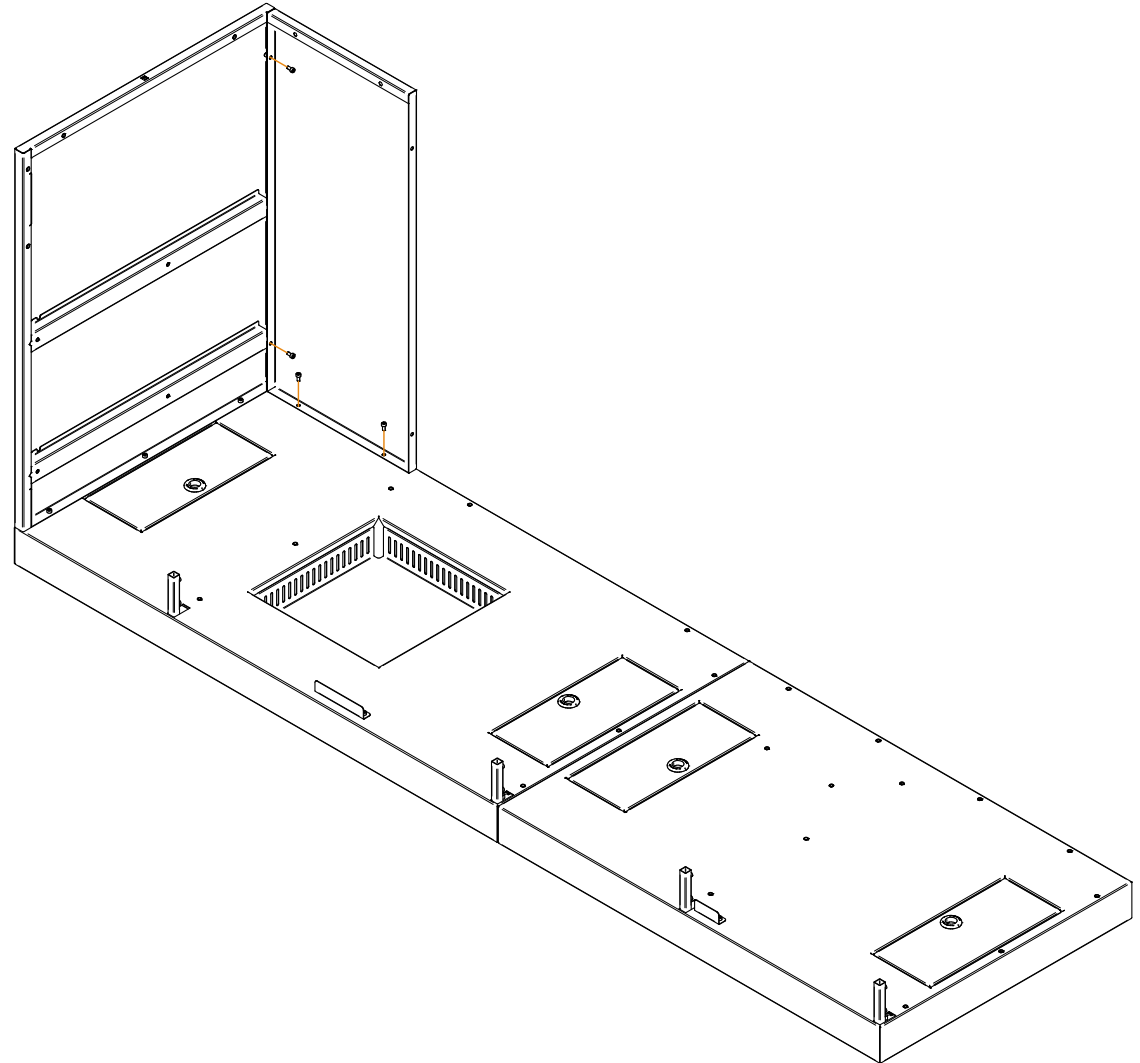

# INSTRUCTIONS

INSTRUCCIONES / ANWEISUNGEN / INSTRUCTIONS / ISTRUZIONI

# BRABURA

GRILLS

**07**

**Step**  
**Paso**  
**Schritt**  
**Étape**  
**Passo**

**LITE Series 400**  
Flank N2 + L-Base  
Flank N2 + Burner Rear

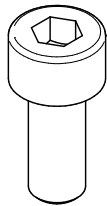

COMPONENT	QUANTITY
SCREW M5x10	7

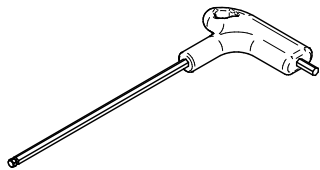

TOOLS REQUIRED
ALLEN WRENCH

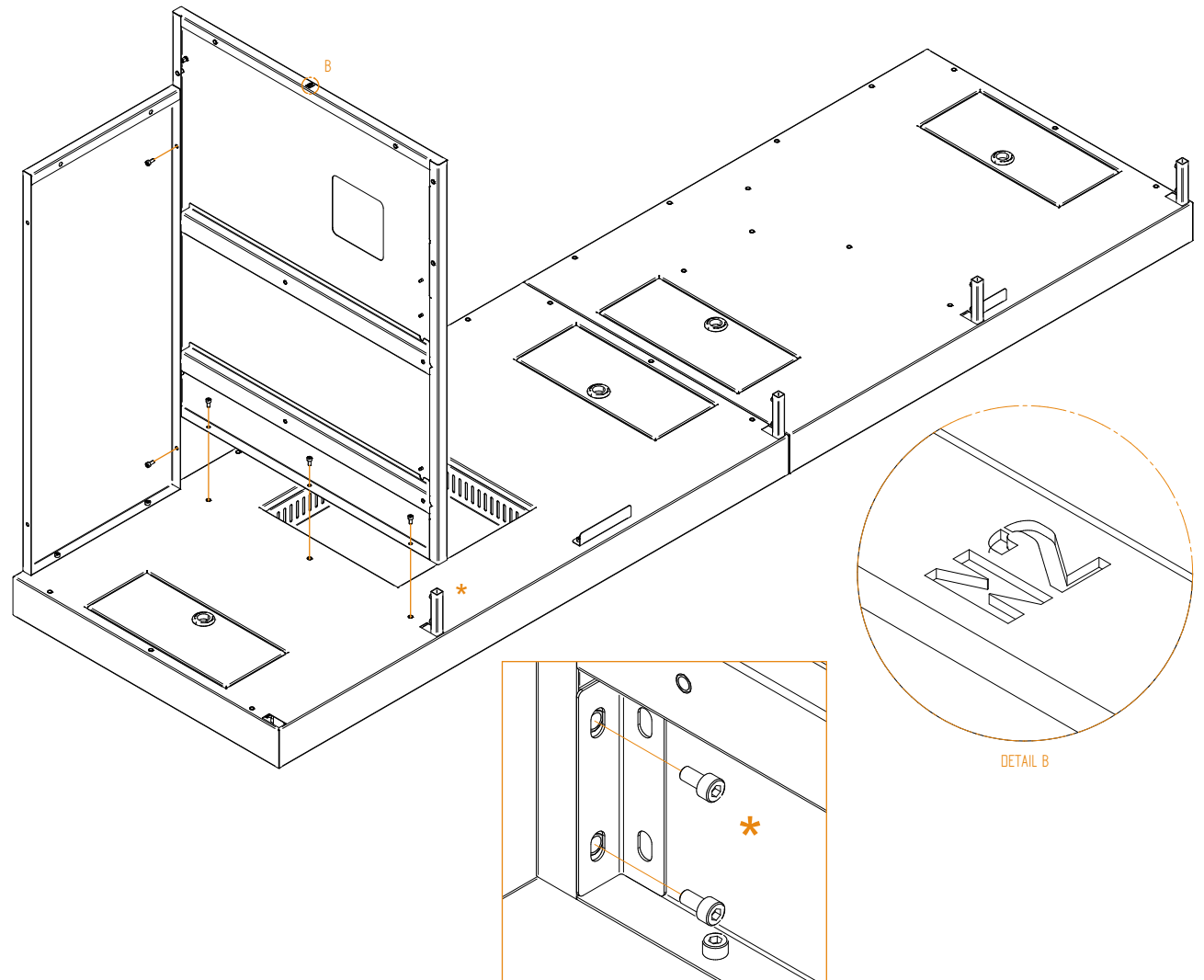

# INSTRUCTIONS

INSTRUCCIONES / ANWEISUNGEN / INSTRUCTIONS / ISTRUZIONI

# BRABURA

GRILLS

**08**

Step  
Paso  
Schritt  
Étape  
Passo

**LITE Series 400**  
Grill Rear + L-Base  
Grill Rear + Grill Rear

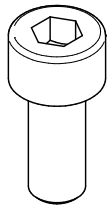

COMPONENT	QUANTITY
SCREW M5x10	4

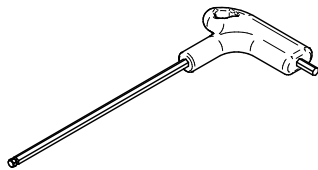

TOOLS REQUIRED
ALLEN WRENCH

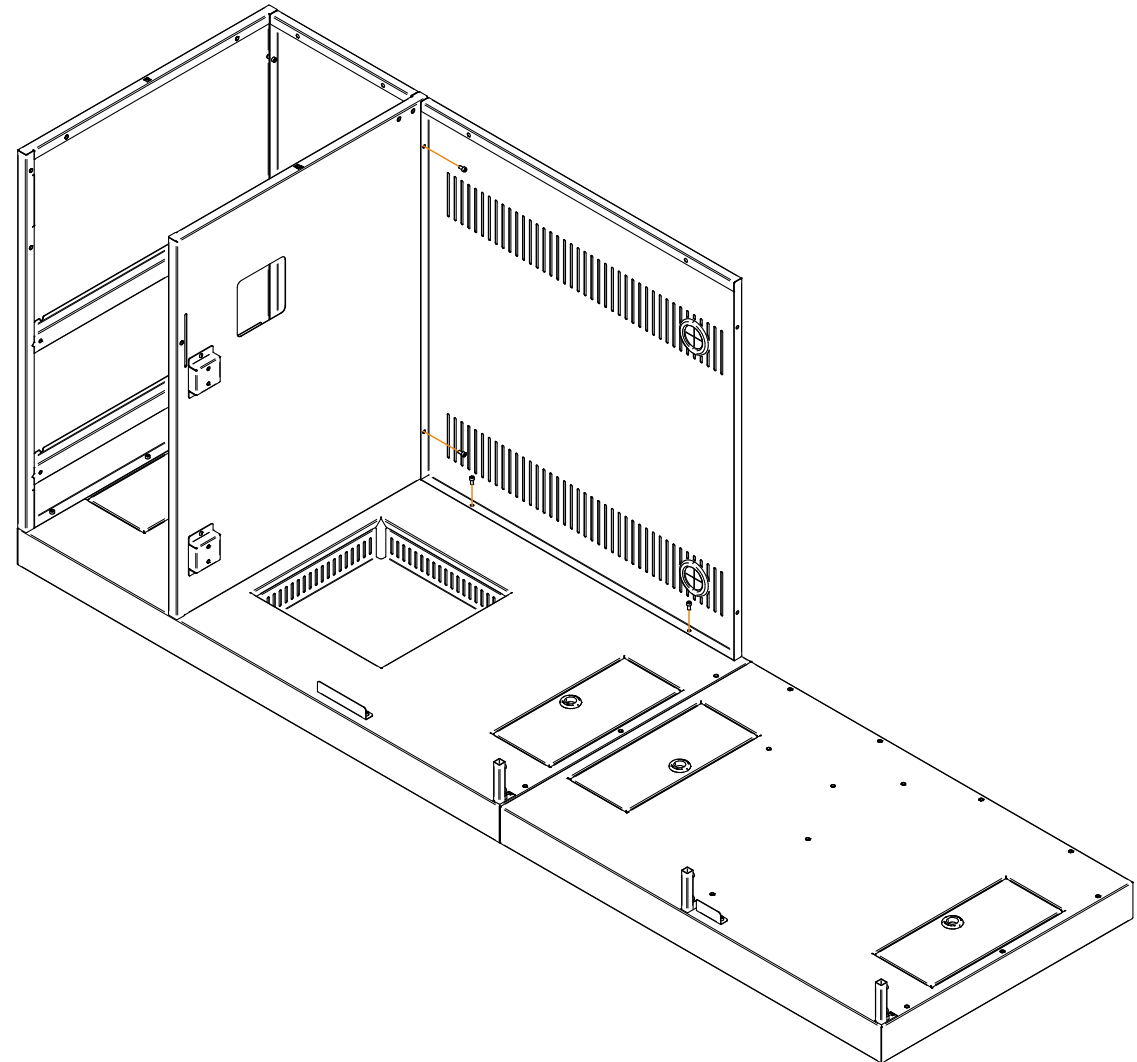

# INSTRUCTIONS

INSTRUCCIONES / ANWEISUNGEN / INSTRUCTIONS / ISTRUZIONI

# BRABURA

GRILLS

**09**

Step  
Paso  
Schritt  
Étape  
Passo

**LITE Series 400**  
Flank N3 + L-Base  
Flank N3 + Grill Rear

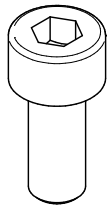

COMPONENT	QUANTITY
SCREW M5x10	7

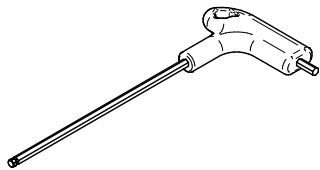

TOOLS REQUIRED
ALLEN WRENCH

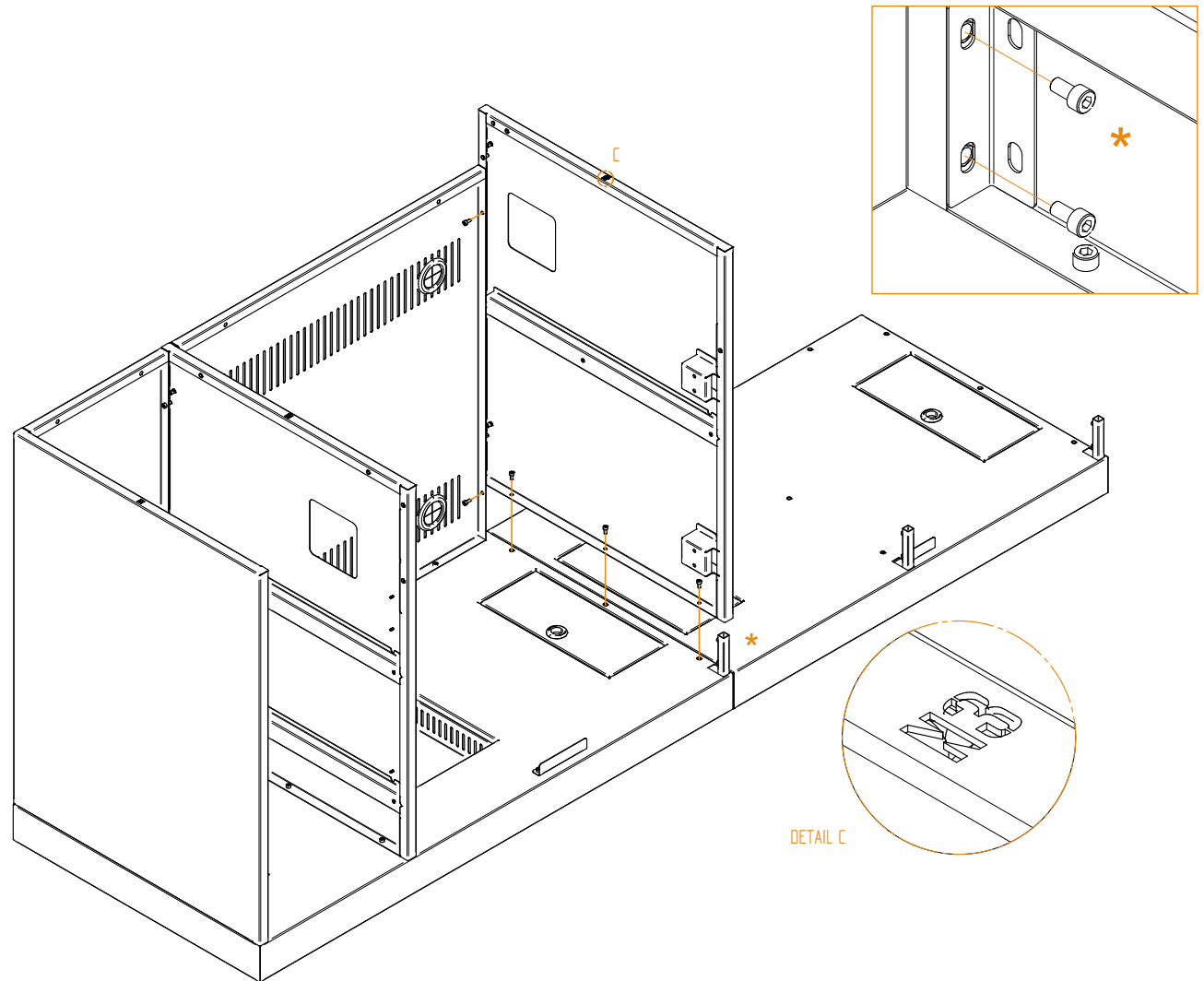

# INSTRUCTIONS

INSTRUCCIONES / ANWEISUNGEN / INSTRUCTIONS / ISTRUZIONI

# BRABURA

GRILLS

**10**

Step  
Paso  
Schritt  
Étape  
Passo

**LITE Series 400**  
Fridge Rear + R-Base  
Fridge Rear + Flank N3  
Fridge Place Positioner + R-Base

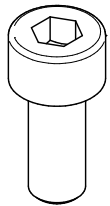

COMPONENT	QUANTITY
SCREW M5x10	4

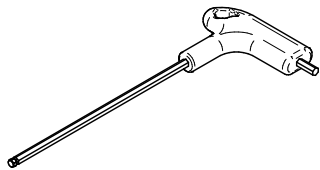

TOOLS REQUIRED
ALLEN WRENCH

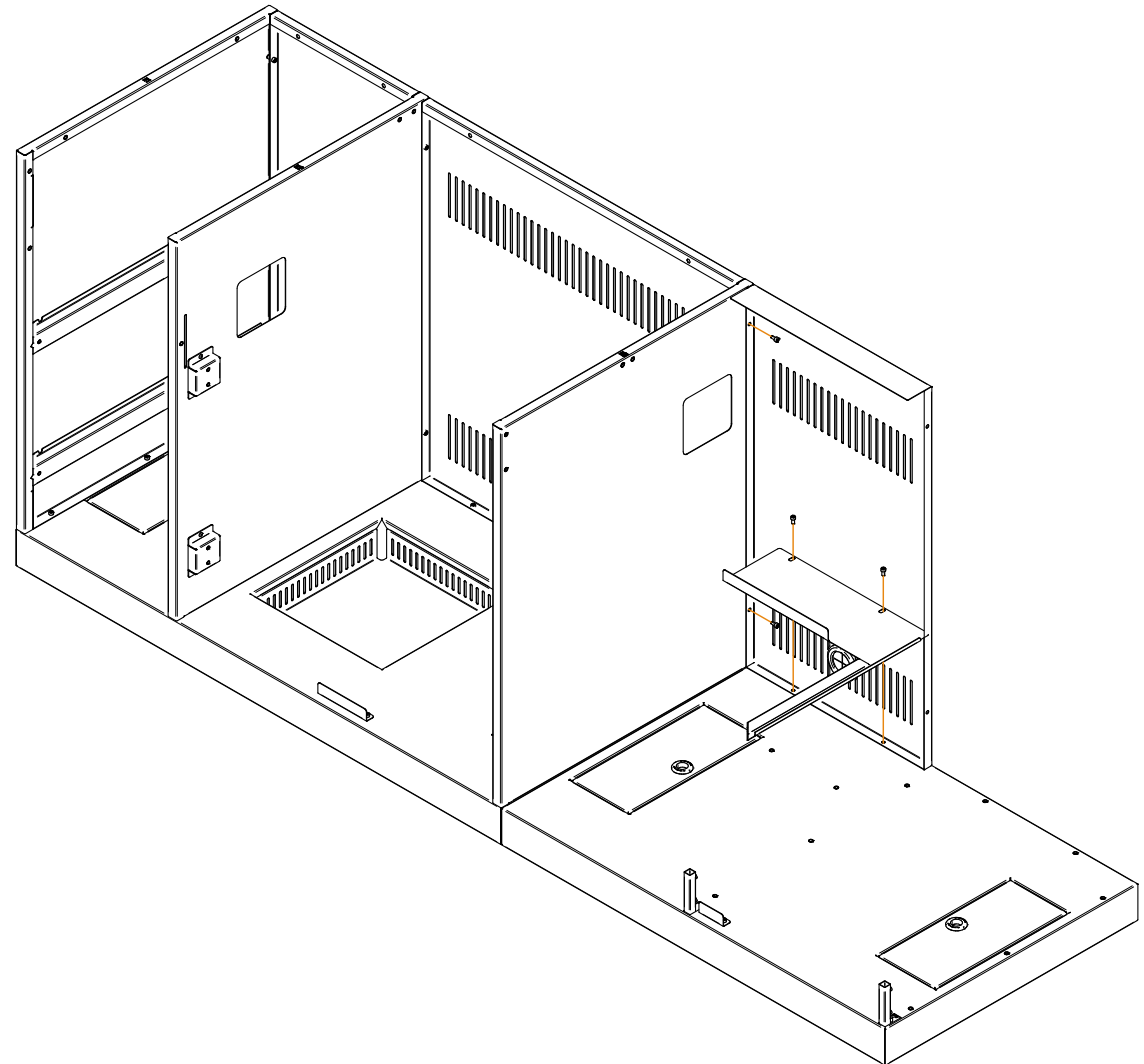

# INSTRUCTIONS

INSTRUCCIONES / ANWEISUNGEN / INSTRUCTIONS / ISTRUZIONI

# BRABURA

GRILLS

**11**

Step  
Paso  
Schritt  
Étape  
Passo

**LITE Series 400**  
Flank N4 + R-Base  
Flank N4 + Fridge Rear

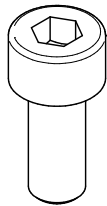
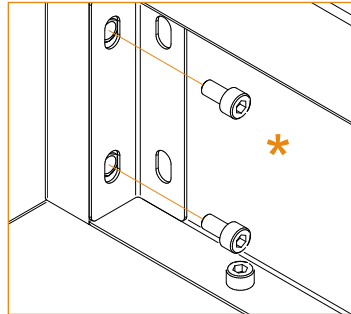

COMPONENT	QUANTITY
SCREW M5x10	7

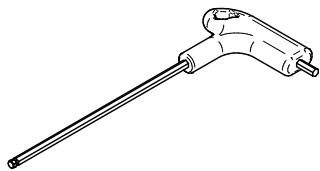

TOOLS REQUIRED
ALLEN WRENCH

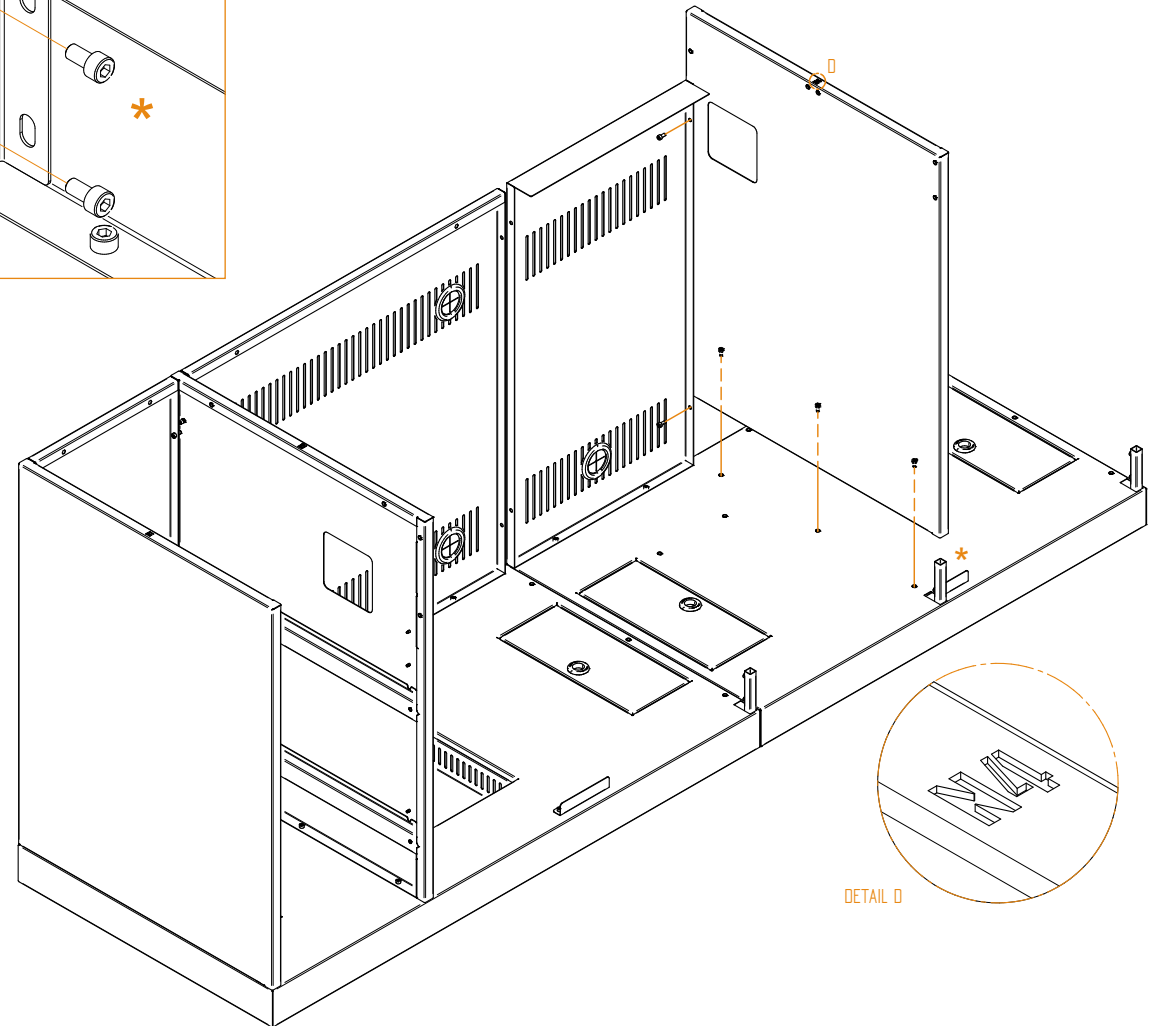

# INSTRUCTIONS

INSTRUCCIONES / ANWEISUNGEN / INSTRUCTIONS / ISTRUZIONI

# BRABURA

GRILLS

**12**

Step  
Paso  
Schritt  
Étape  
Passo

**LITE Series 400**  
Sink Rear + R-Base  
Sink Rear + Flank N4  
Register Top + Sink Rear

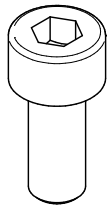

COMPONENT	QUANTITY
SCREW M5x10	8

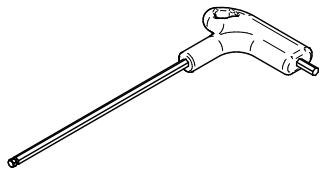

TOOLS REQUIRED
ALLEN WRENCH

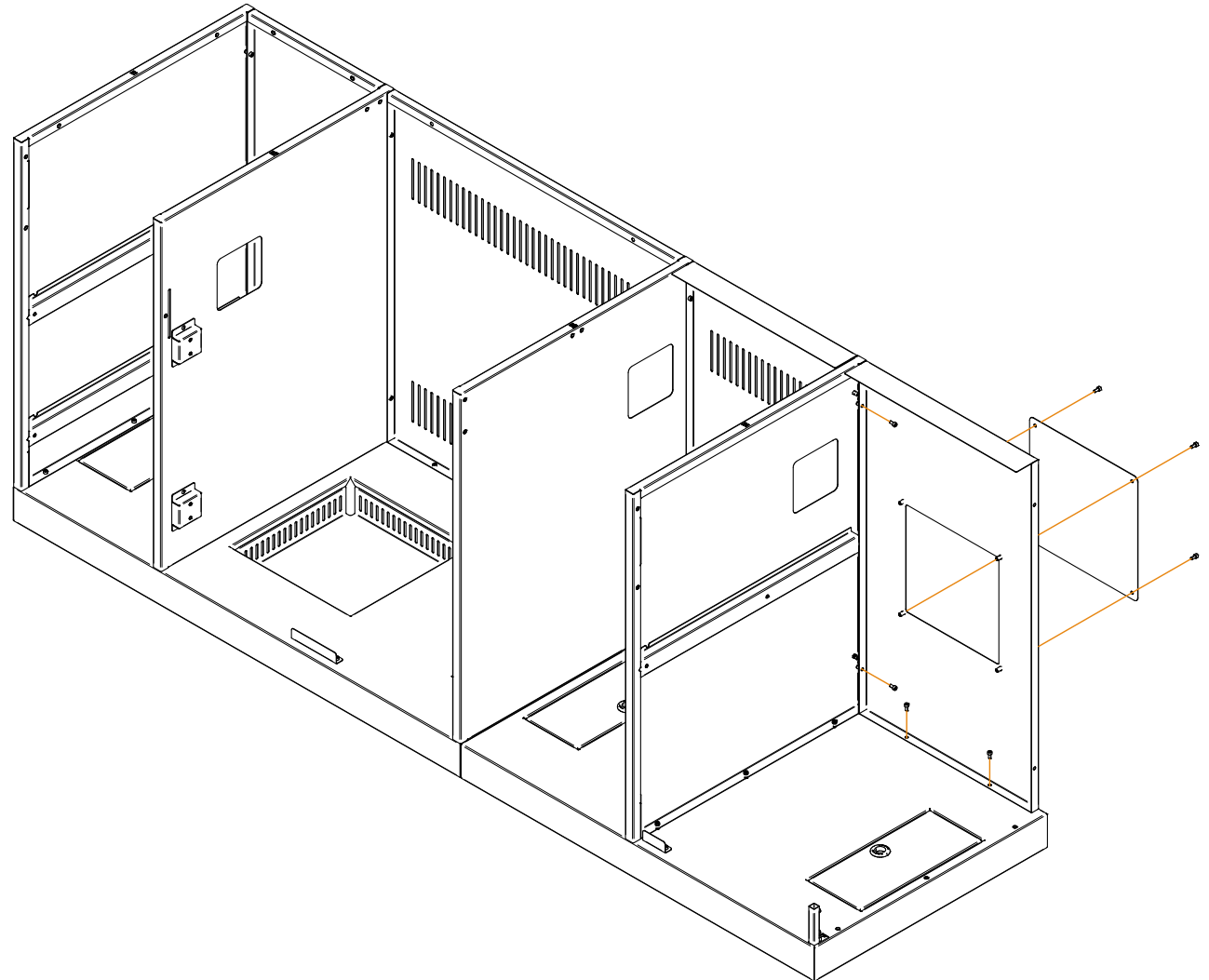

# INSTRUCTIONS

INSTRUCCIONES / ANWEISUNGEN / INSTRUCTIONS / ISTRUZIONI

# BRABURA

GRILLS

**13**

Step  
Paso  
Schritt  
Étape  
Passo

**LITE Series 400**  
Flank N5 + R-Base  
Flank N5 + Sink Rear

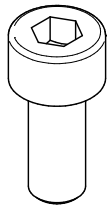

COMPONENT	QUANTITY
SCREW M5x10	7

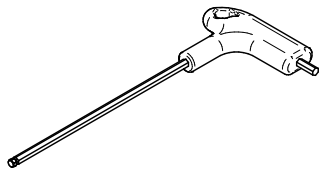

TOOLS REQUIRED
ALLEN WRENCH

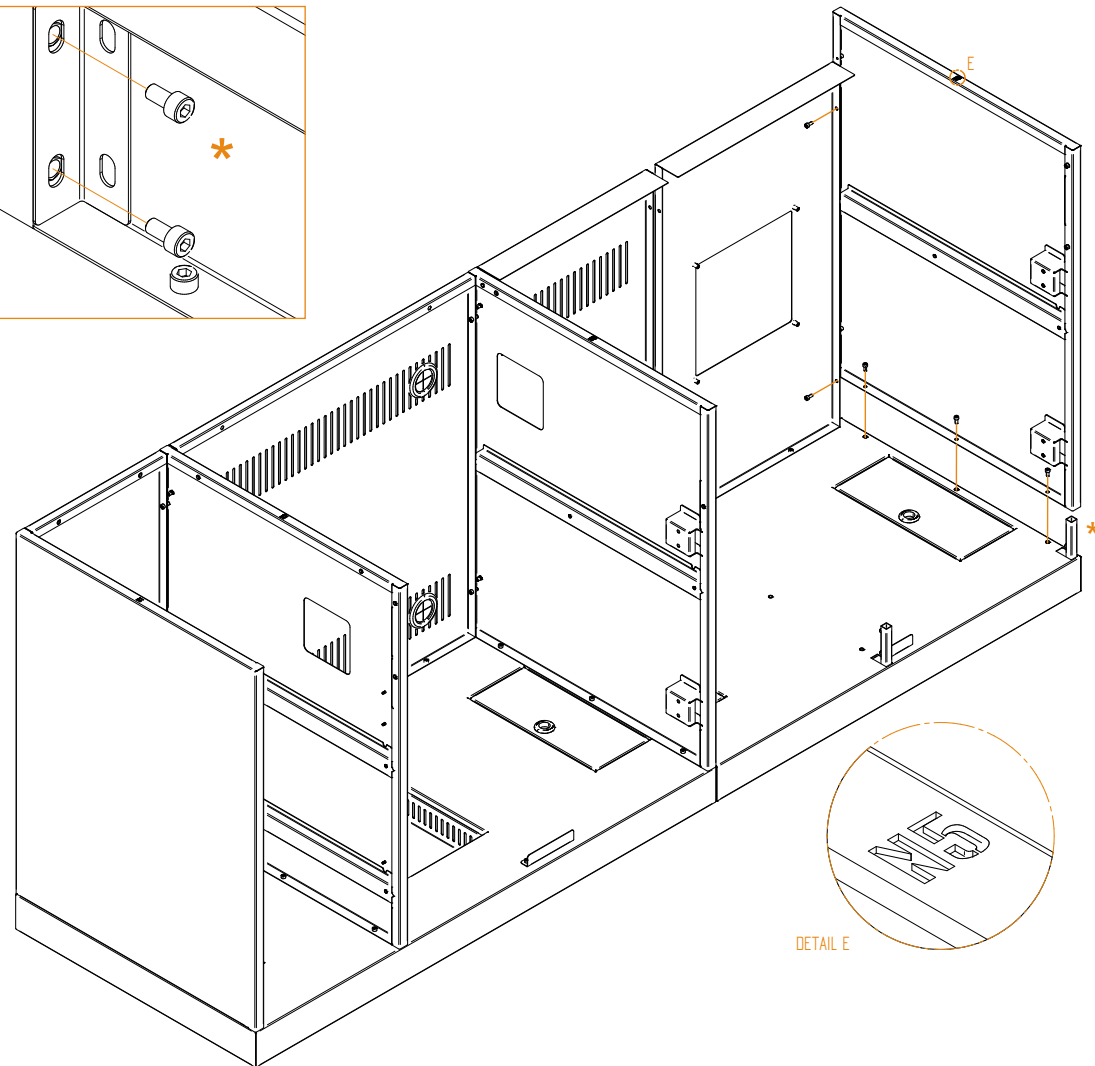
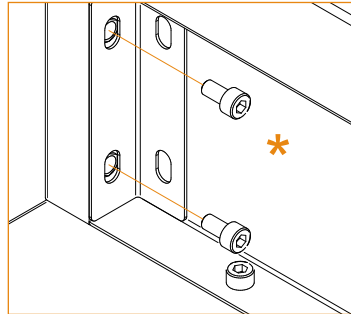

# INSTRUCTIONS

INSTRUCCIONES / ANWEISUNGEN / INSTRUCTIONS / ISTRUZIONI

# BRABURA

GRILLS

**14**

**Step**  
**Paso**  
**Schritt**  
**Étape**  
**Passo**

## LITE Series 400

Grill Stone Support + Flank N2  
Grill Stone Support + Flank N3  
Grill Stone Support + Grill Rear  
Fridge Stone Support + Flank N3  
Fridge Stone Support + Flank N4

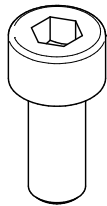

COMPONENT	QUANTITY
SCREW M5x10	10

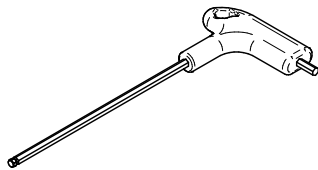

TOOLS REQUIRED
ALLEN WRENCH

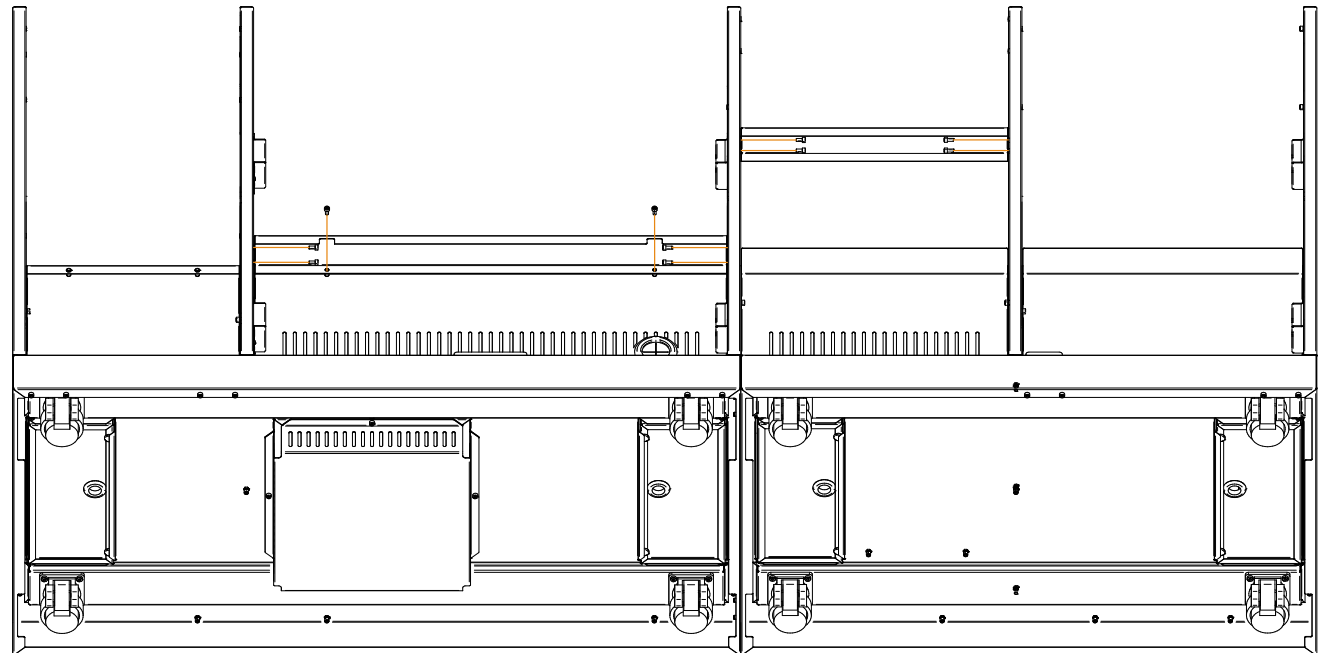

# INSTRUCTIONS

INSTRUCCIONES / ANWEISUNGEN / INSTRUCTIONS / ISTRUZIONI

# BRABURA

GRILLS

**15**

**Step**  
**Paso**  
**Schritt**  
**Étape**  
**Passo**

**LITE Series 400**  
Bottle Opener + Sink Rib  
Magnet + Sink Rib  
Magnet (2) + Grill Rib

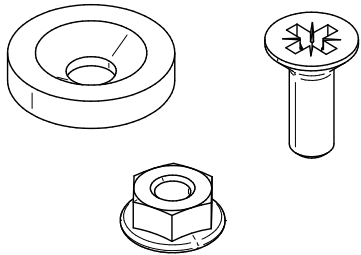

COMPONENTS	QUANTITY
COUNTERSUNK SCREW M4x10	3
MAGNET	3
M4 NUT	7

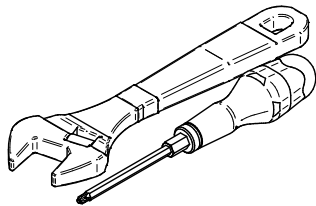

TOOLS REQUIRED
ADJUSTABLE WRENCH
SCREWDRIVER PHILLIPS-TIP

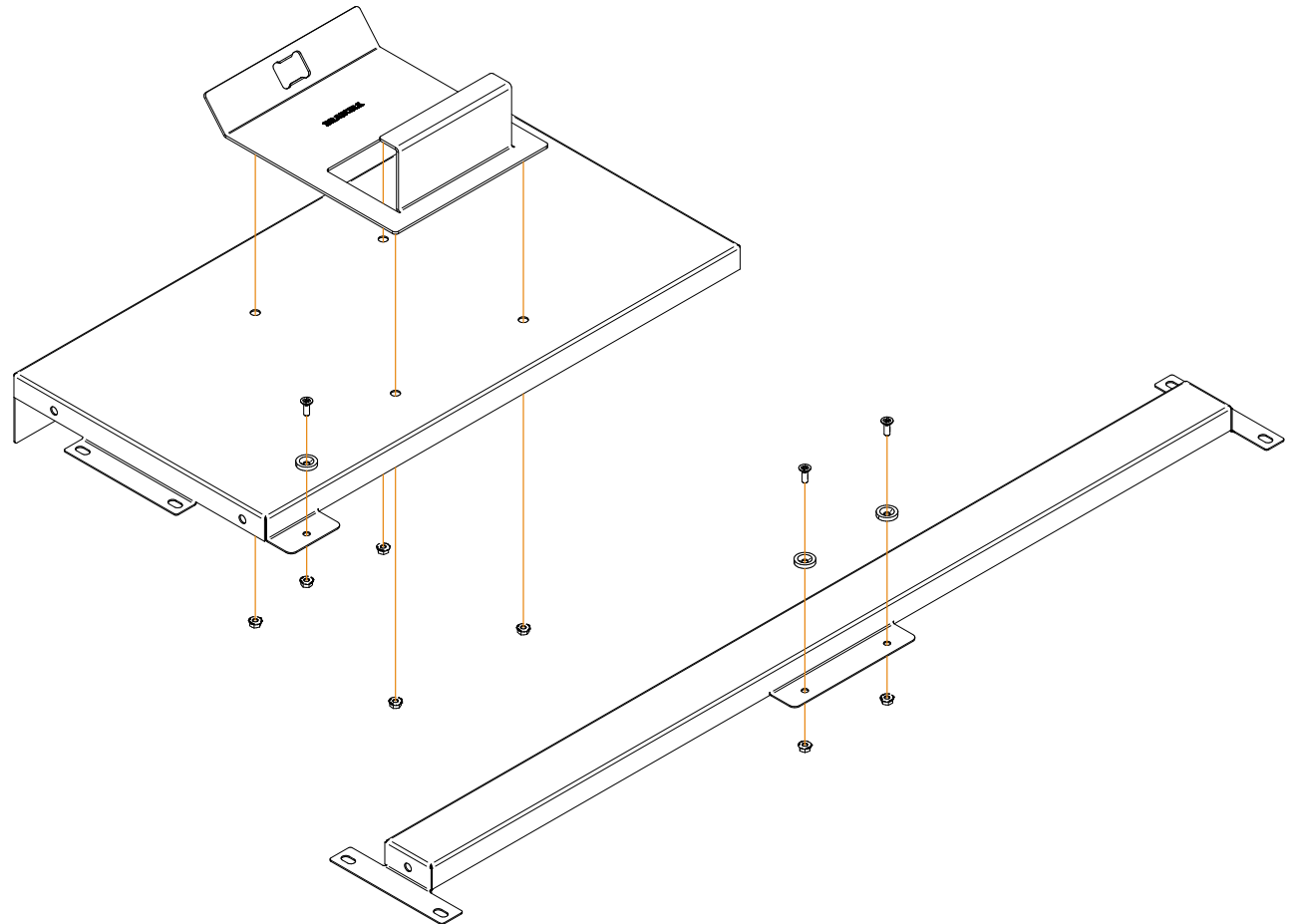

# INSTRUCTIONS

INSTRUCCIONES / ANWEISUNGEN / INSTRUCTIONS / ISTRUZIONI

# BRABURA

GRILLS

## 16

Step  
Paso  
Schritt  
Étape  
Passo

**LITE Series 400**  
Grill Rib + Flank N2  
Grill Rib + Flank N3  
Fridge Rib + Flank N3  
Fridge Rib + Flank N4  
Sink Rib + Flank N4  
Sink Rib + Flank N5

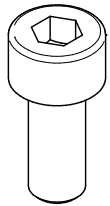

COMPONENT	QUANTITY
SCREW M5x10	18

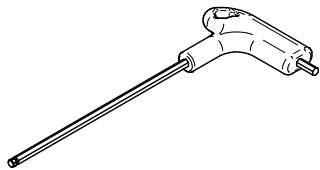

TOOLS REQUIRED
ALLEN WRENCH

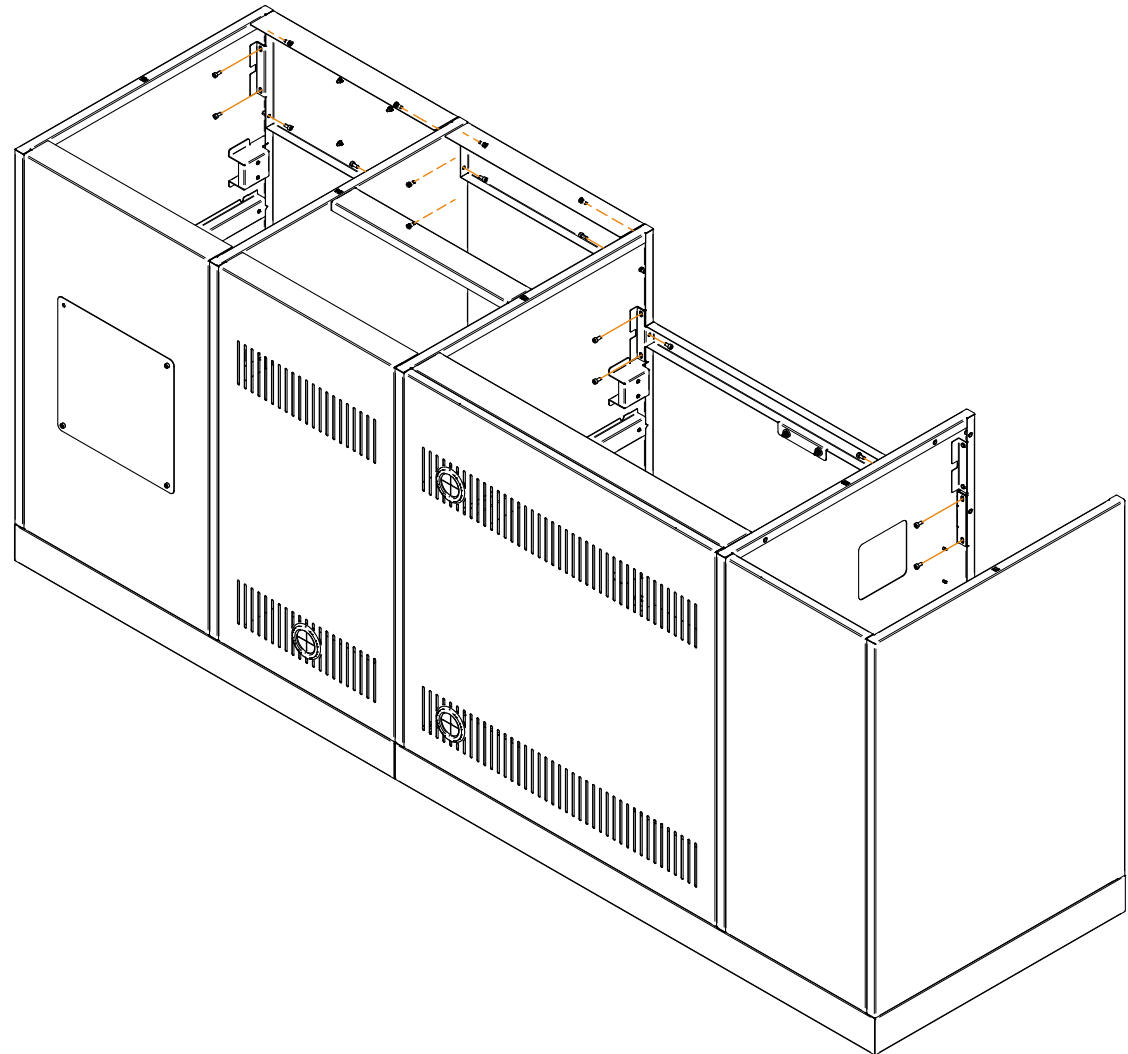

# INSTRUCTIONS

INSTRUCCIONES / ANWEISUNGEN / INSTRUCTIONS / ISTRUZIONI

# BRABURA

GRILLS

17

Step  
Paso  
Schritt  
Étape  
Passo

LITE Series 400

Drawers Guide (2) + Flank N1

Drawers Guide (2) + Flank N2

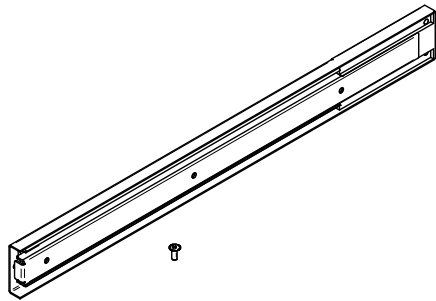

COMPONENTS	QUANTITY
DRAWERS GUIDE	4
FLATHEAD SCREW M4x10	8

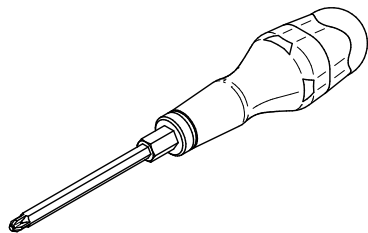

TOOLS REQUIRED
SCREWDRIVER PHILLIPS-TIP

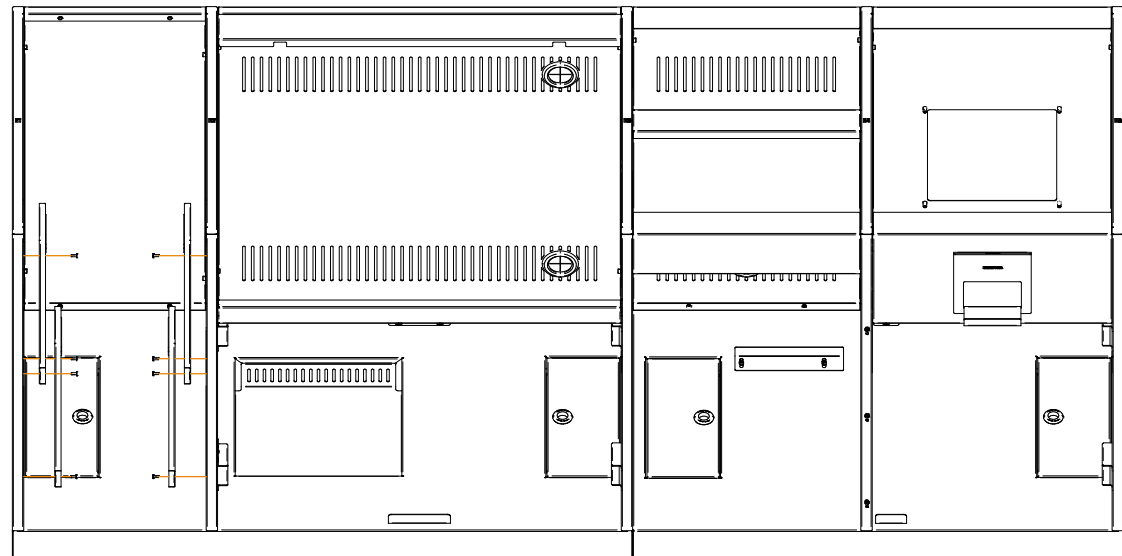
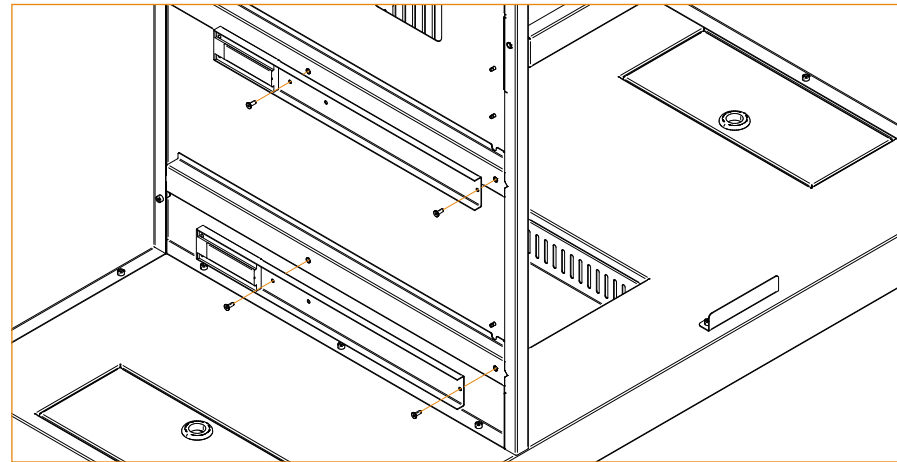

# INSTRUCTIONS

INSTRUCCIONES / ANWEISUNGEN / INSTRUCTIONS / ISTRUZIONI

# BRABURA

GRILLS

**18**

Step  
Paso  
Schritt  
Étape  
Passo

**LITE Series 400**  
Burner + Flank N1  
Burner + Flank N2  
Knob + Bezel + Burner

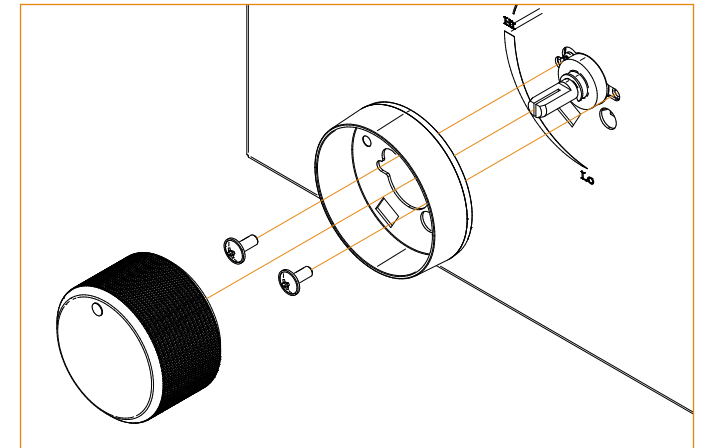
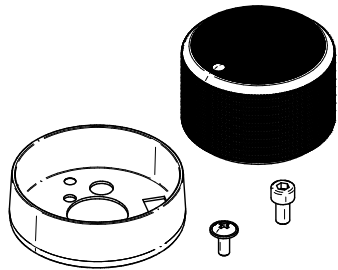

COMPONENTS	QUANTITY
KNOB	1
BEZEL	1
SCREW M5x10	14
ROUNDHEAD SCREW M4x10	2

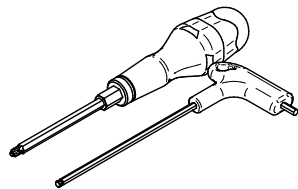

TOOLS REQUIRED
ADJUSTABLE WRENCH
SCREWDRIVER PHILLIPS-TIP

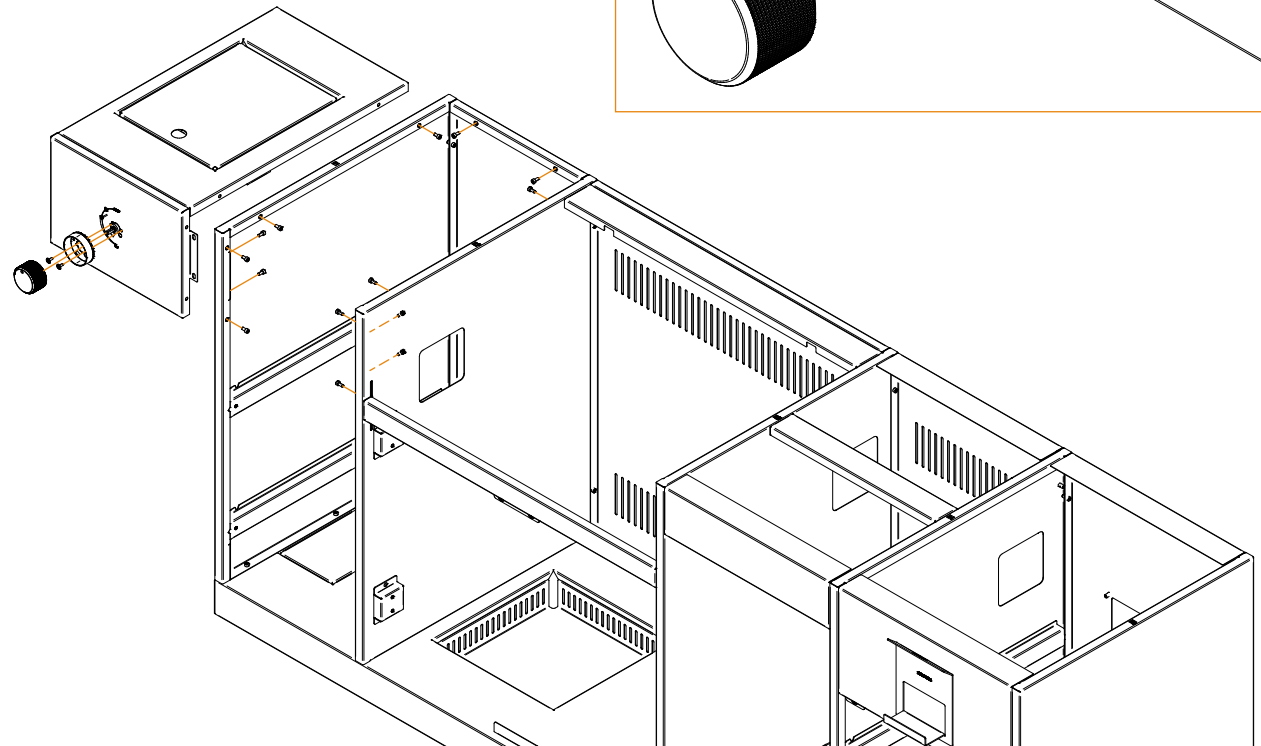

# INSTRUCTIONS

INSTRUCCIONES / ANWEISUNGEN / INSTRUCTIONS / ISTRUZIONI

# BRABURA

GRILLS

**19**

Step  
Paso  
Schritt  
Étape  
Passo

## LITE Series 400

Drawer Door (2) + Drawer (2)  
Drawers Guide (4) + Drawer (2)  
Handle (2) + Drawer Door (2)

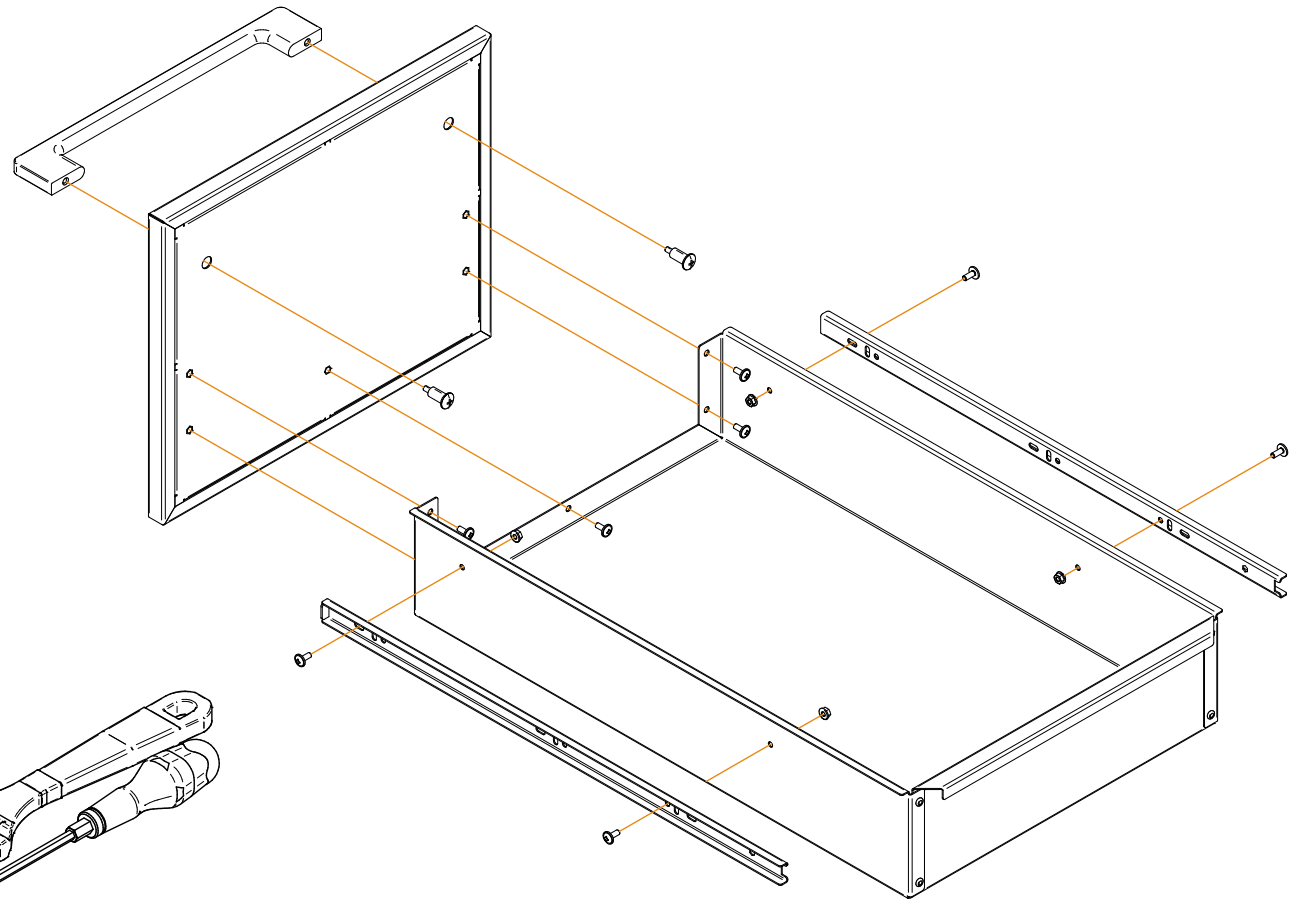
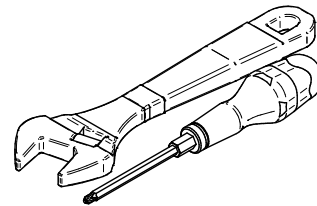
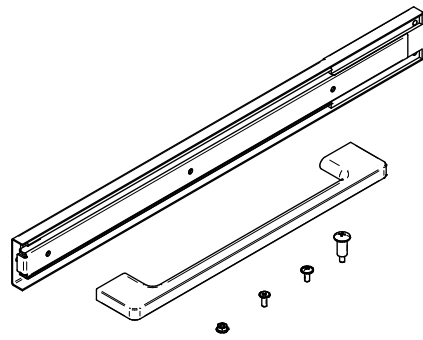

COMPONENTS	QUANTITY
DRAWERS GUIDE	4
HANDLE	2
FLATHEAD SCREW M4x10	8
M4 NUT	8
ROUNDHEAD SCREW 8x16 M4x7	4
ROUNDHEAD SCREW M4x10	10

TOOLS REQUIRED
ADJUSTABLE WRENCH
SCREWDRIVER PHILLIPS-TIP

# INSTRUCTIONS

INSTRUCCIONES / ANWEISUNGEN / INSTRUCTIONS / ISTRUZIONI

**BRABURA**  
GRILLS

**20**

Step  
Paso  
Schritt  
Étape  
Passo

LITE Series 400  
Drawer + Drawers Guide

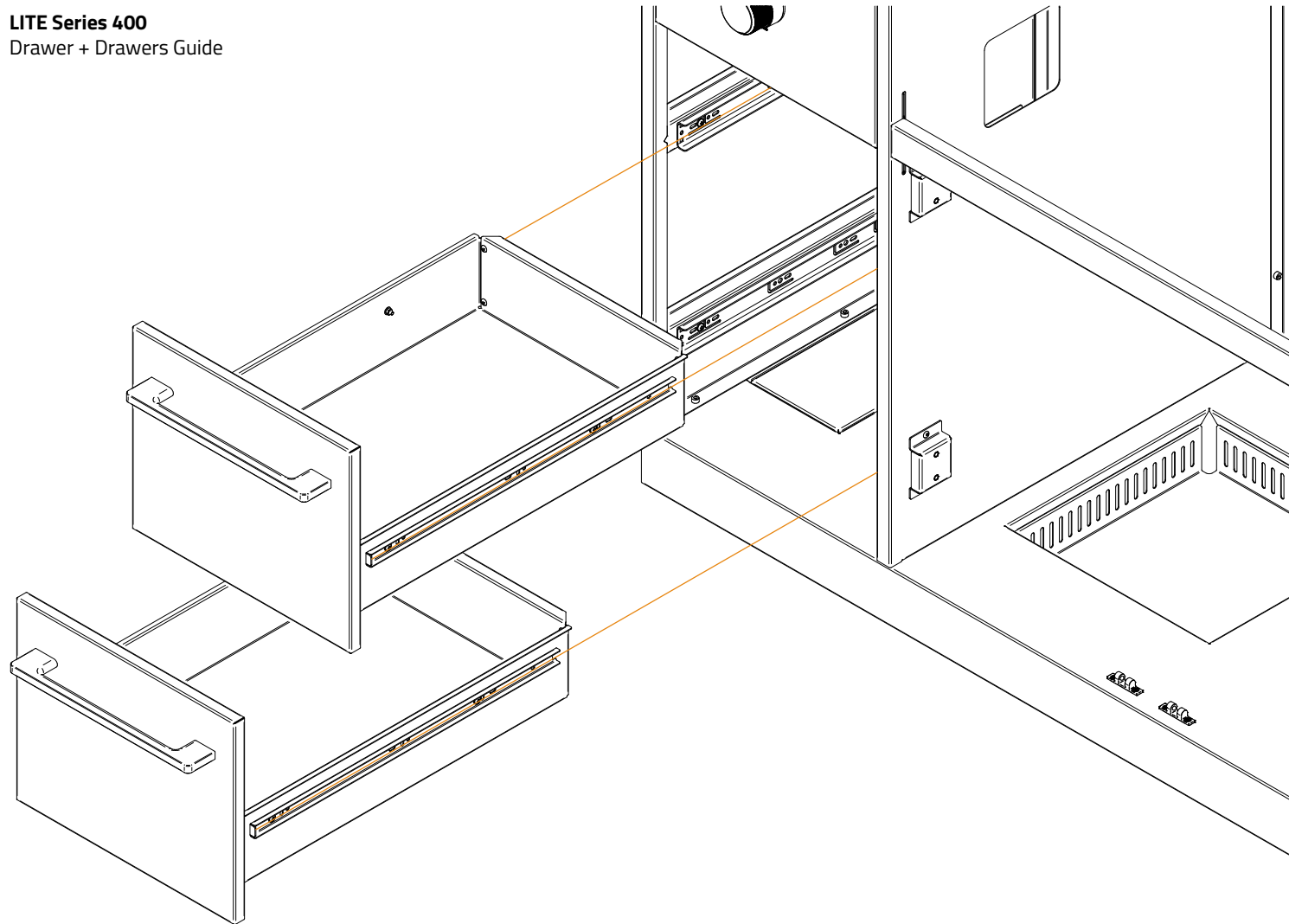

# INSTRUCTIONS

INSTRUCCIONES / ANWEISUNGEN / INSTRUCTIONS / ISTRUZIONI

**BRABURA**  
GRILLS

**21**

**Step** LITE Series 400  
**Paso** Bin Frame + Bin Door  
**Schritt** Handle + Bin Door  
**Étape** Paper-Towel Support + R-Door  
**Passo** Handle + R-Door  
 Handle + L-Door

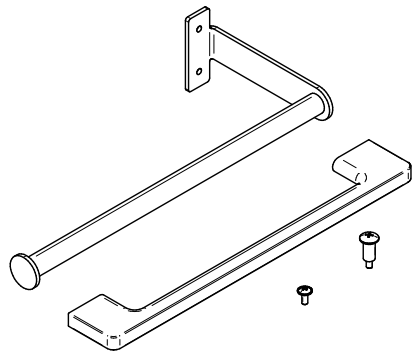

COMPONENTS	QUANTITY
PAPER-TOWEL SUPPORT	1
HANDLE	3
ROUNDHEAD SCREW 8x16 M4x7	6
ROUNDHEAD SCREW M4x10	6

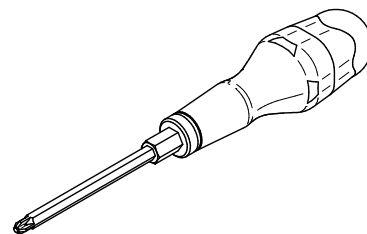

TOOLS REQUIRED
SCREWDRIVER PHILLIPS-TIP

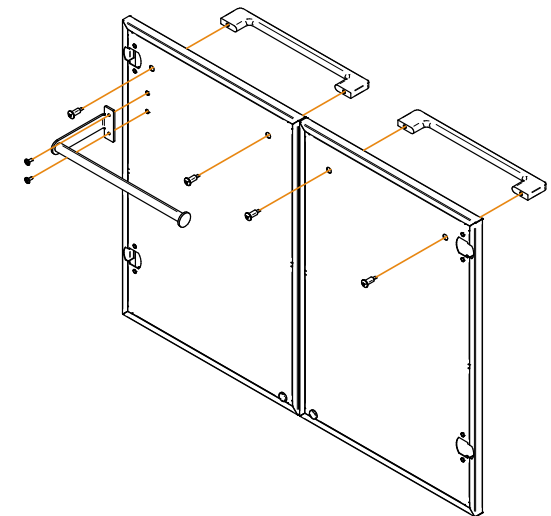
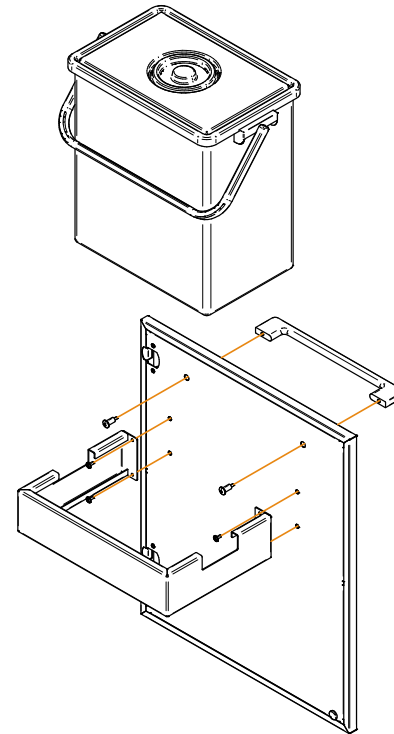

# INSTRUCTIONS

INSTRUCCIONES / ANWEISUNGEN / INSTRUCTIONS / ISTRUZIONI

# BRABURA

GRILLS

**22**

- Step Hinge (2) + Flank N2
- Paso Hinge (2) + L-Door
- Schritt Hinge (2) + Flank N3
- Étape Hinge (2) + R-Door
- Passo Hinge (2) + Flank N5
- Hinge (2) + Bin Door

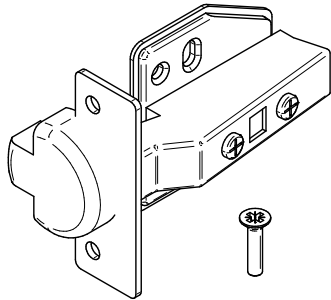

COMPONENTS	QUANTITY
HINGE	6
COUNTERSUNK SCREW M4x16	24

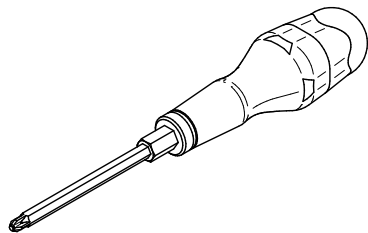

TOOLS REQUIRED
SCREWDRIVER PHILLIPS-TIP

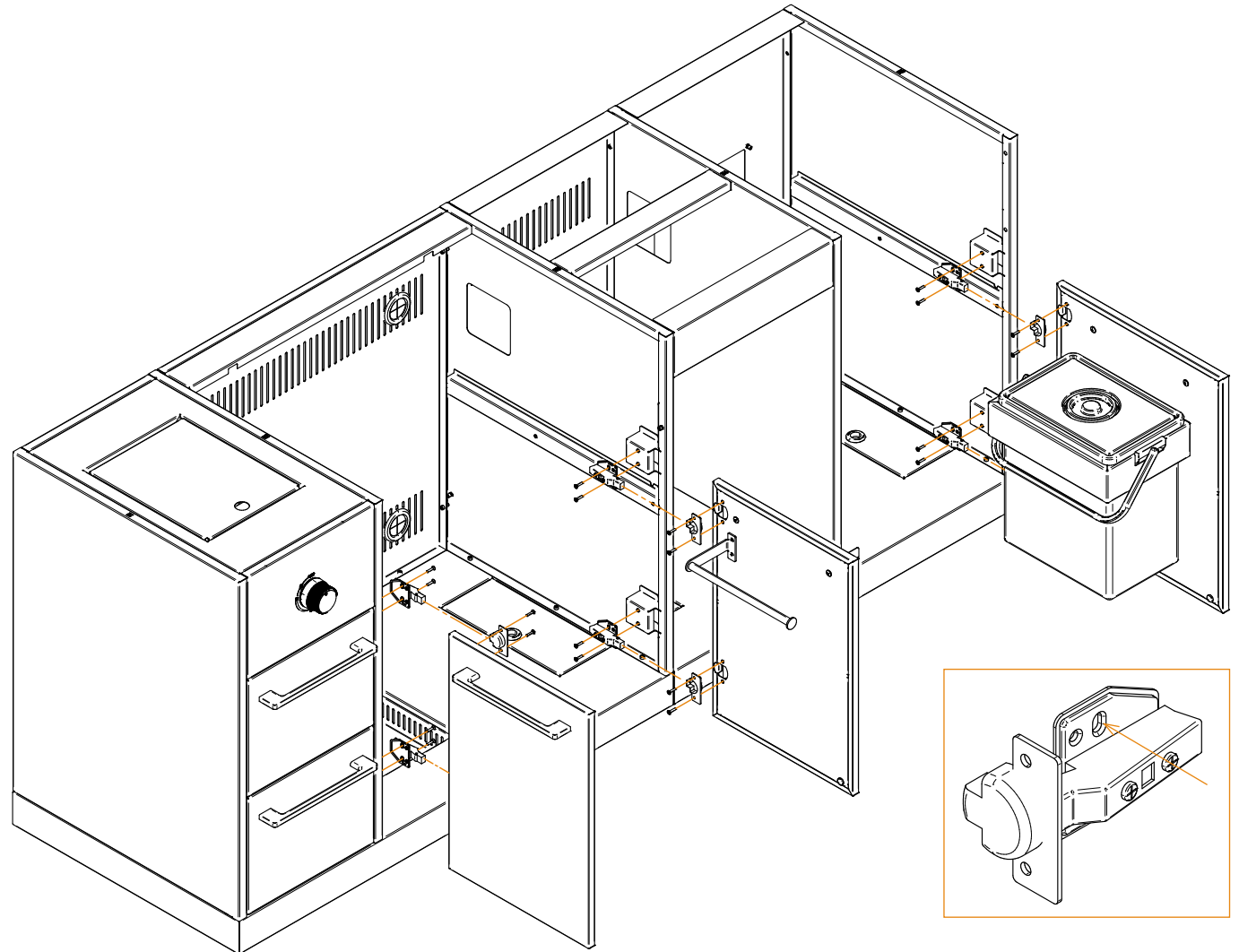

# INSTRUCTIONS

INSTRUCCIONES / ANWEISUNGEN / INSTRUCTIONS / ISTRUZIONI

# BRABURA

GRILLS

**01**

Step  
Paso  
Schritt  
Étape  
Passo

**LITE Series 300**  
Wheel-Mounted Leg (4) + L-Base  
Grill Door Stopper + L-Base

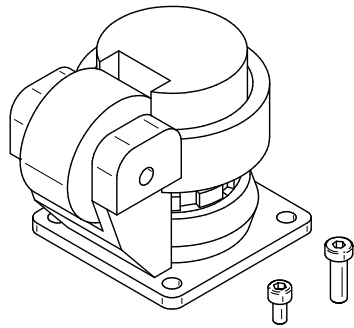

COMPONENTS	QUANTITY
WHEEL-MOUNTED LEG	4
SCREW M6x20	16
SCREW M5x10	2

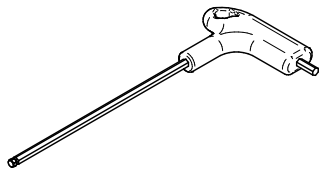

TOOLS REQUIRED

ALLEN WRENCH

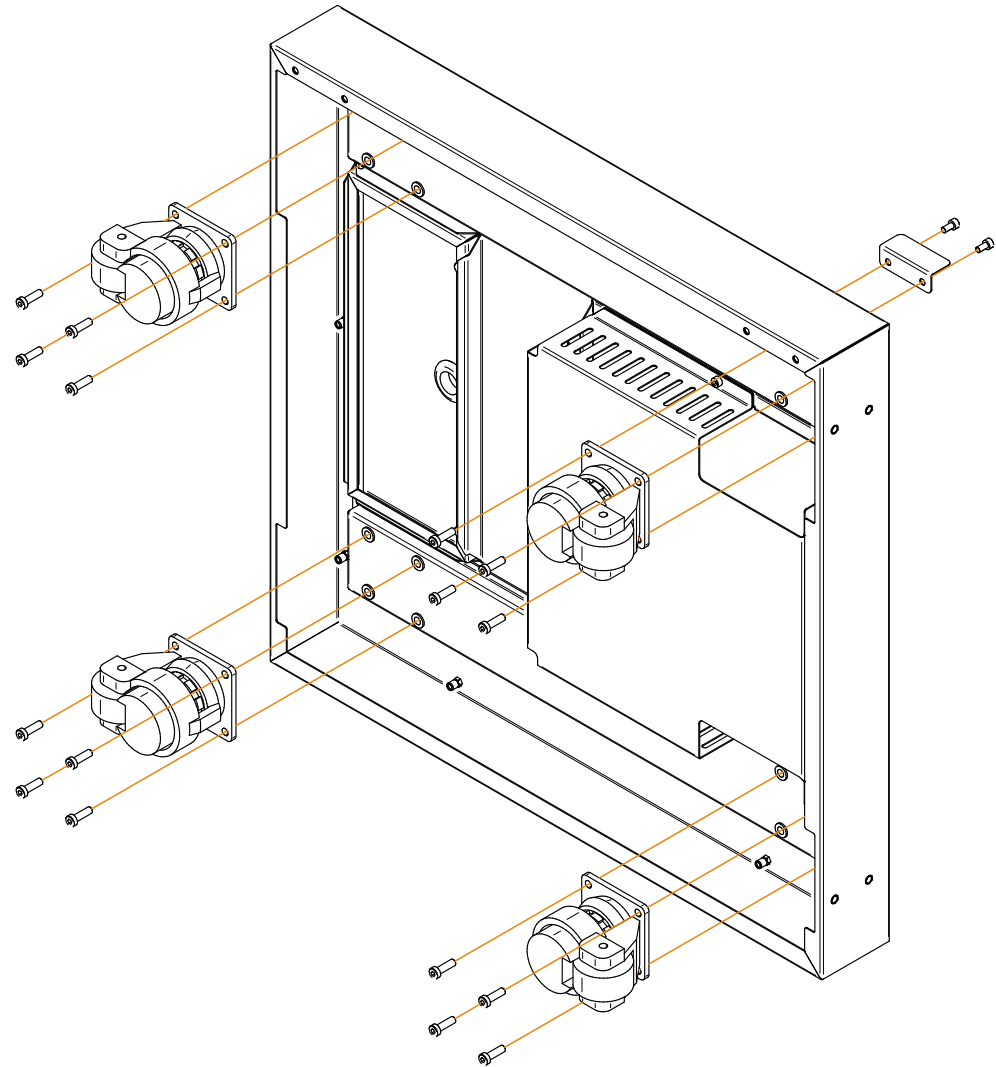

# INSTRUCTIONS

INSTRUCCIONES / ANWEISUNGEN / INSTRUCTIONS / ISTRUZIONI

# BRABURA

GRILLS

## 02

- Step** LITE Series 300
- Paso** L-Base + R-Base
- Schritt** Wheel-Mounted Leg (2) + R-Base
- Étape** Bin Door Stopper + R-Base
- Passo**

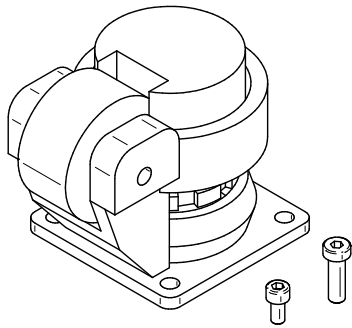

COMPONENTS	QUANTITY
WHEEL-MOUNTED LEG	2
SCREW M6x20	8
SCREW M5x10	6

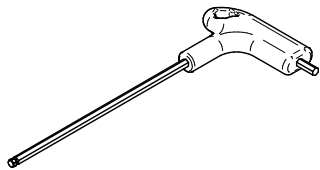

TOOLS REQUIRED
ALLEN WRENCH

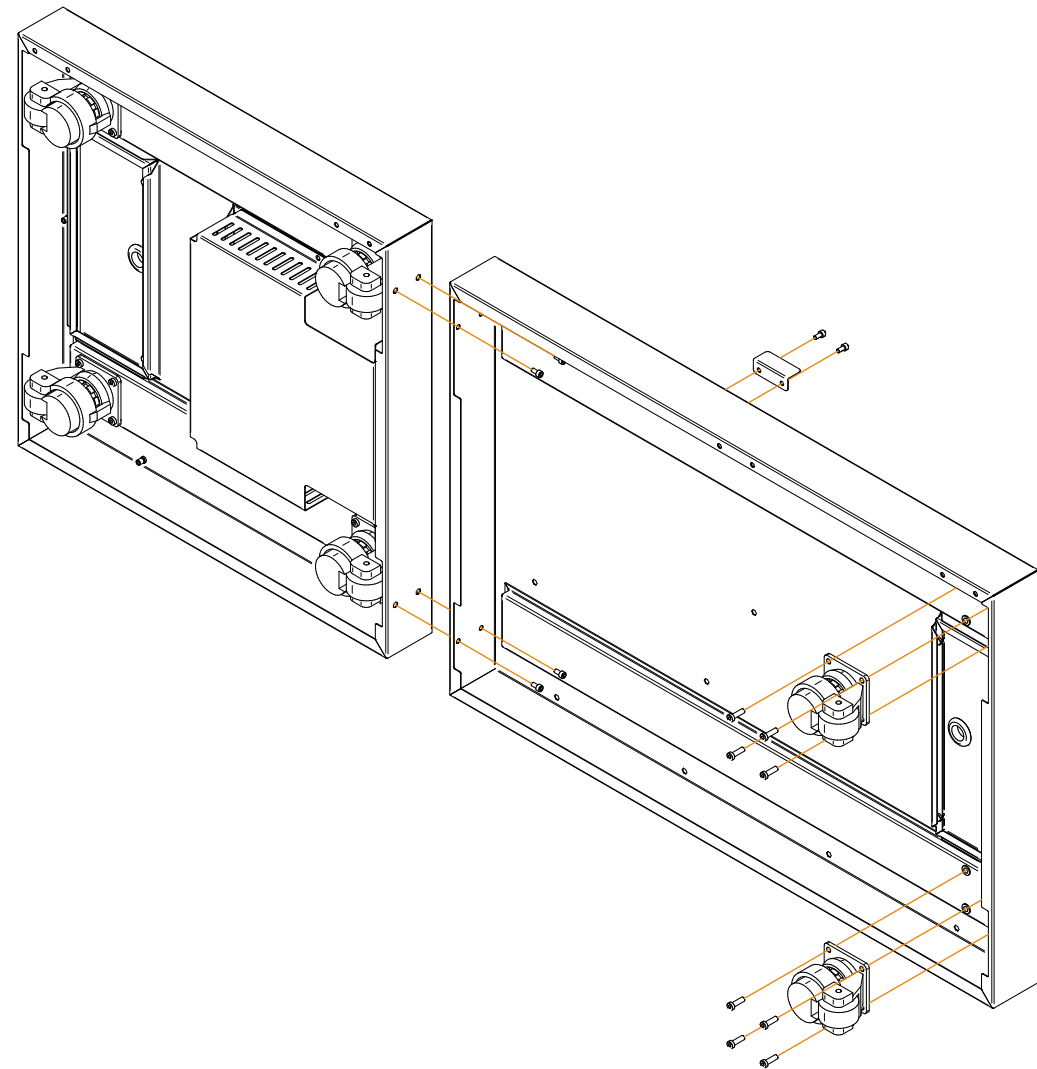

# INSTRUCTIONS

INSTRUCCIONES / ANWEISUNGEN / INSTRUCTIONS / ISTRUZIONI

# BRABURA

GRILLS

**03**

Step  
Paso  
Schritt  
Étape  
Passo

## LITE Series 300

L-Bracket Tube (1) + L-Base

R-Bracket Tube (1) + L-Base

L-Bracket Tube (1) + R-Base

R-Bracket Tube (1) + R-Base

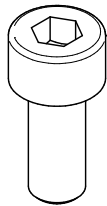

COMPONENT	QUANTITY
SCREW M5x10	8

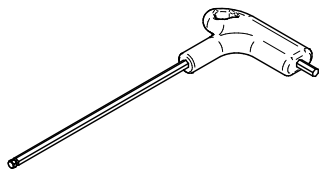

TOOLS REQUIRED
ALLEN WRENCH

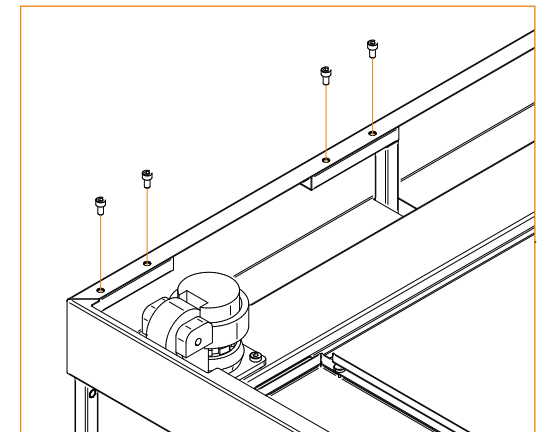
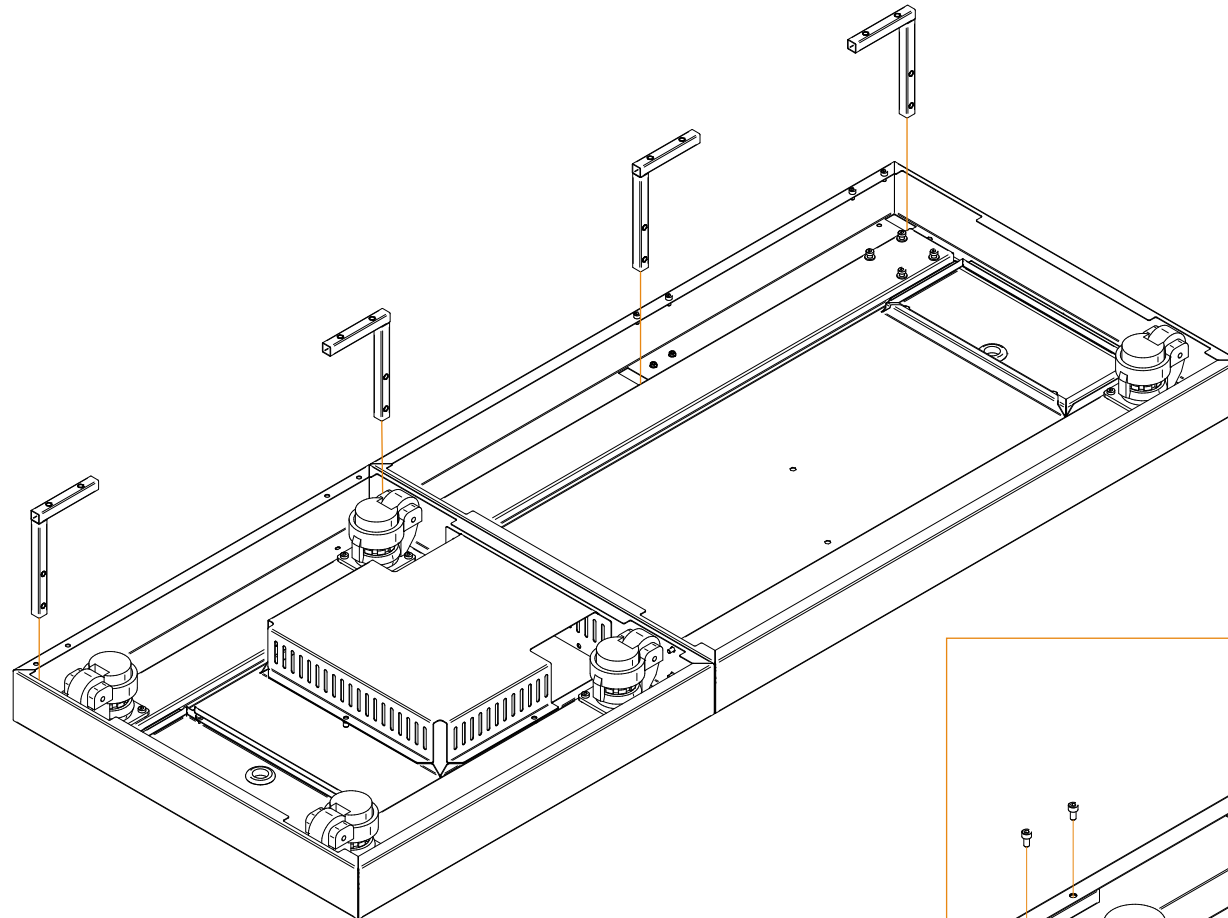

# INSTRUCTIONS

INSTRUCCIONES / ANWEISUNGEN / INSTRUCTIONS / ISTRUZIONI

# BRABURA

GRILLS

**04**

Step  
Paso  
Schritt  
Étape  
Passo

LITE Series 300  
Flank N6 + L-Base

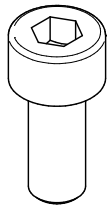

COMPONENT	QUANTITY
SCREW M5x10	5

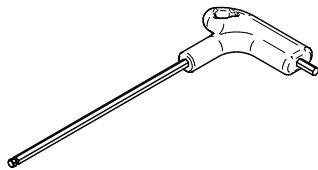

TOOLS REQUIRED
ALLEN WRENCH

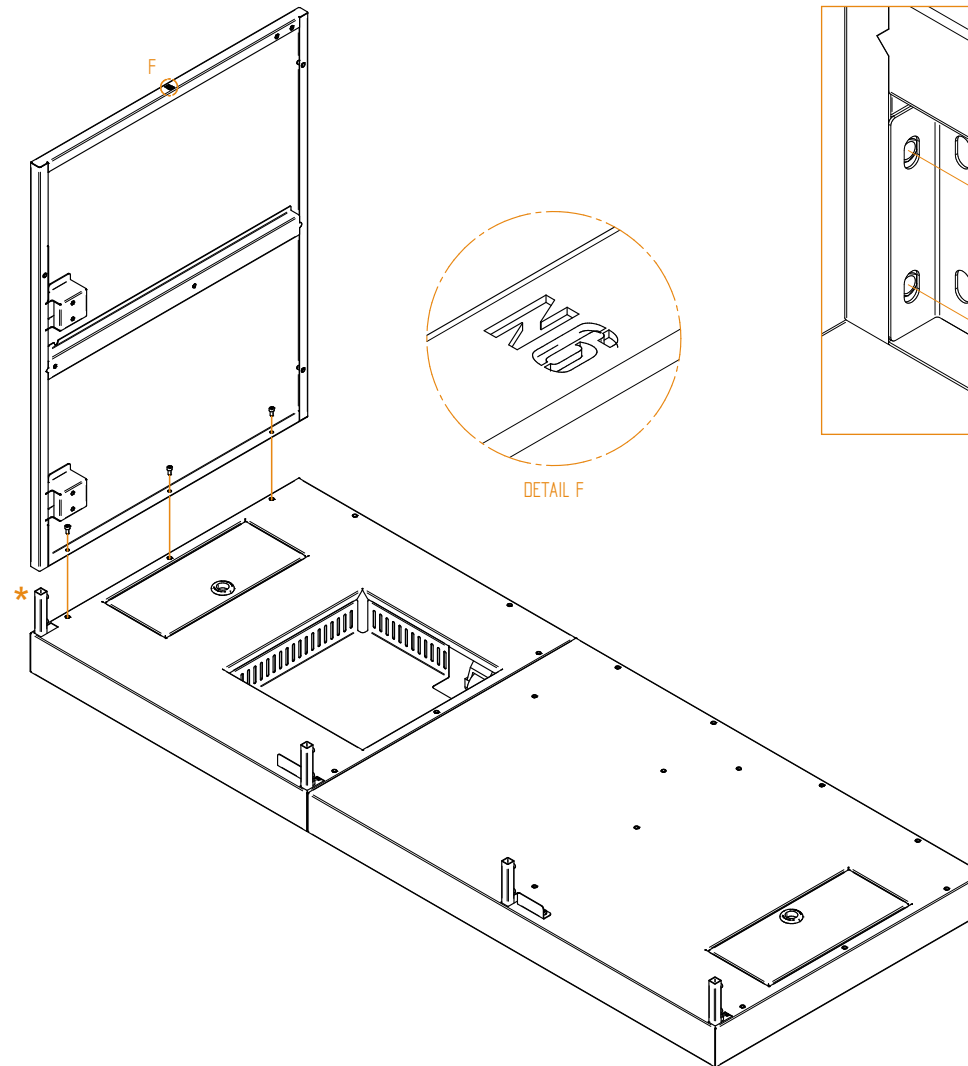

# INSTRUCTIONS

INSTRUCCIONES / ANWEISUNGEN / INSTRUCTIONS / ISTRUZIONI

# BRABURA

GRILLS

**05**

Step  
Paso  
Schritt  
Étape  
Passo

**LITE Series 300**  
Grill Rear + L-Base  
Grill Rear + Flank N6

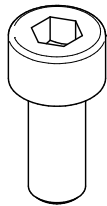

COMPONENT	QUANTITY
SCREW M5x10	4

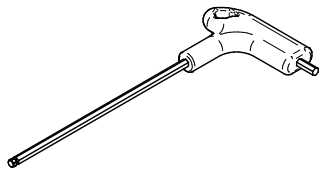

TOOLS REQUIRED
ALLEN WRENCH

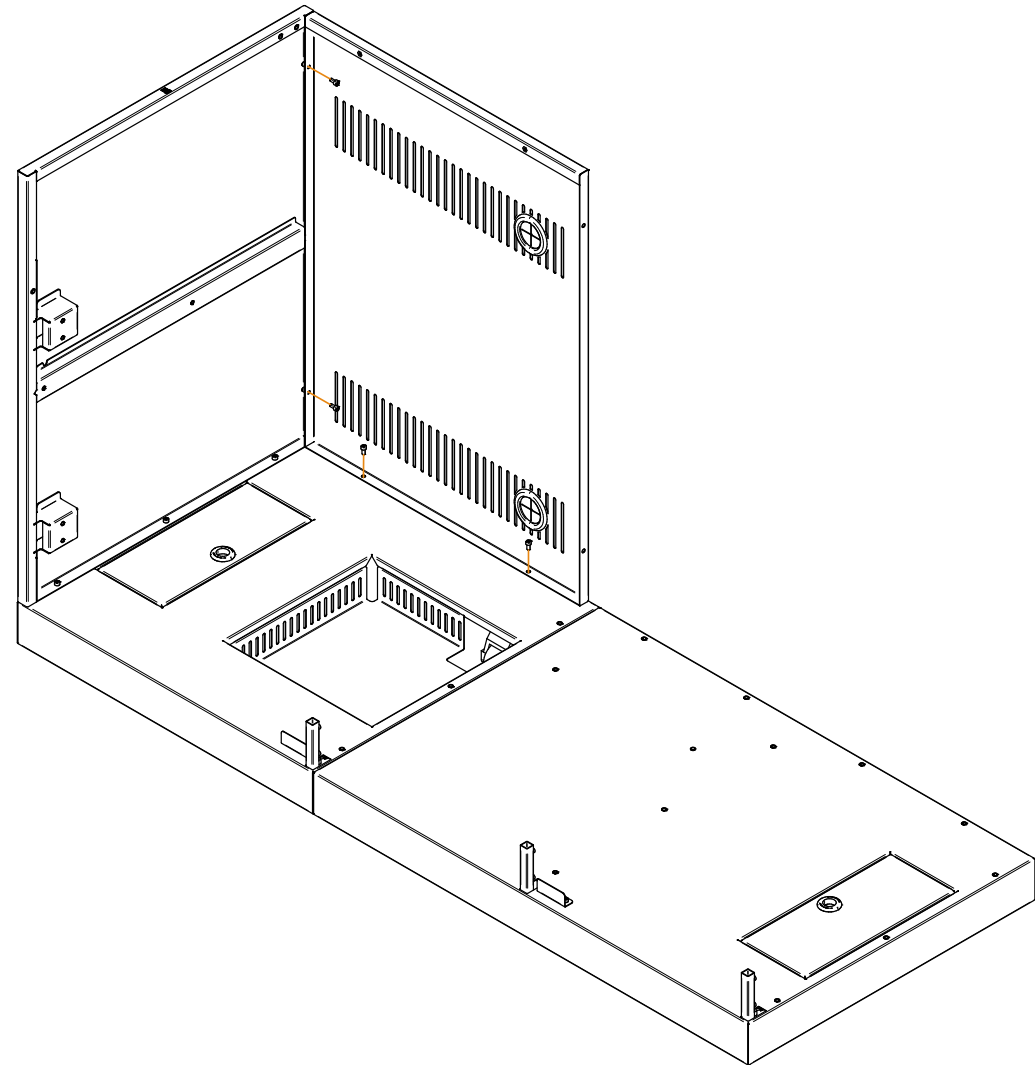

# INSTRUCTIONS

INSTRUCCIONES / ANWEISUNGEN / INSTRUCTIONS / ISTRUZIONI

# BRABURA

GRILLS

**06**

**Step** LITE Series 300  
**Paso** Flank N3 + L-Base  
**Schritt** Flank N3 + Grill Rear  
**Étape**  
**Passo**

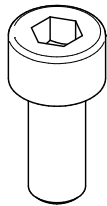

COMPONENT	QUANTITY
SCREW M5x10	7

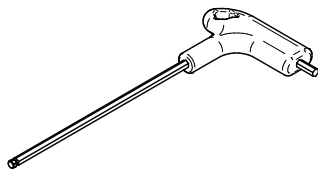

TOOLS REQUIRED
ALLEN WRENCH

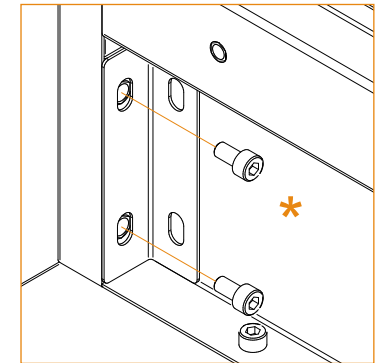
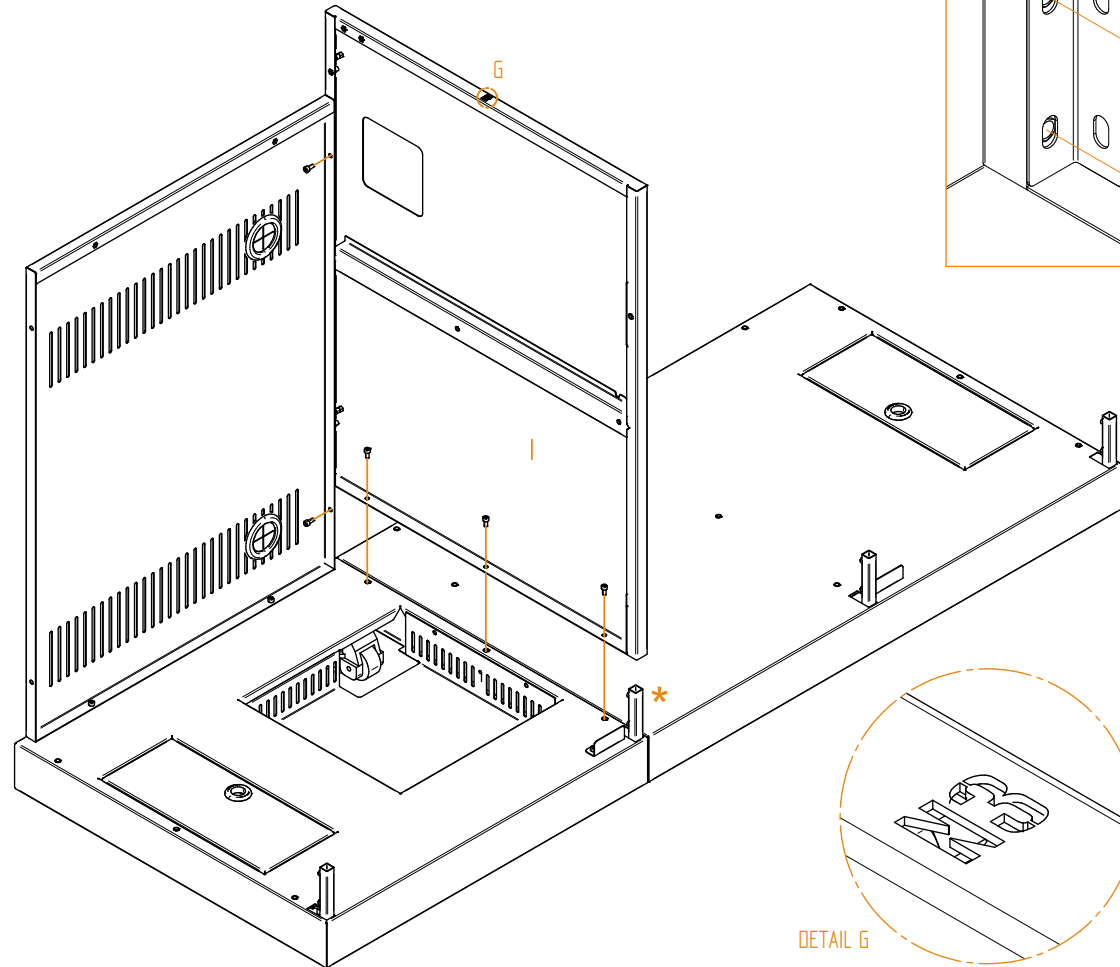

# INSTRUCTIONS

INSTRUCCIONES / ANWEISUNGEN / INSTRUCTIONS / ISTRUZIONI

# BRABURA

GRILLS

## 07

Step  
Paso  
Schritt  
Étape  
Passo

**LITE Series 300**  
Fridge Rear + R-BasE  
Fridge Rear + Flank N3  
Fridge Place Positioner + R-Base

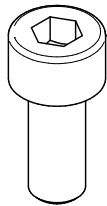

COMPONENT	QUANTITY
SCREW M5x10	4

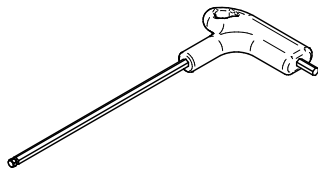

TOOLS REQUIRED
ALLEN WRENCH

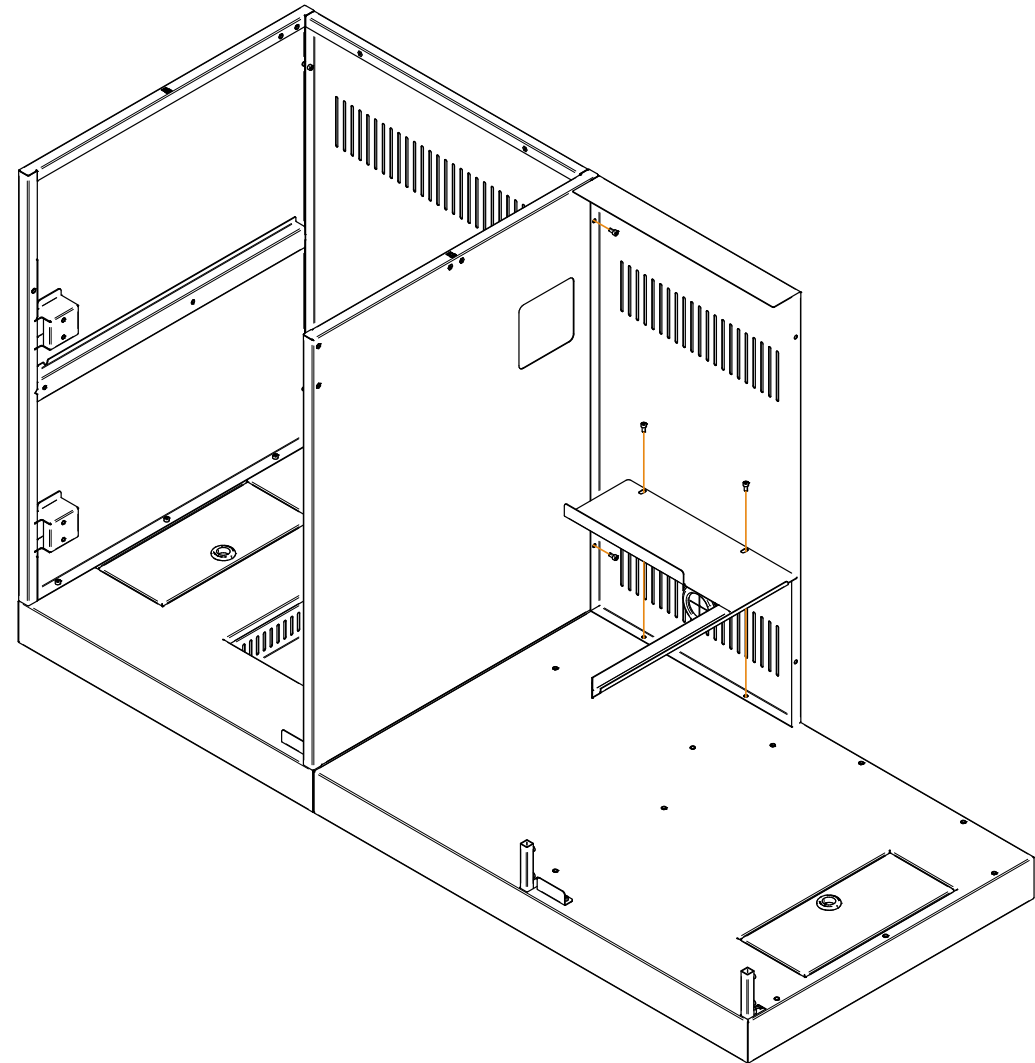

# INSTRUCTIONS

INSTRUCCIONES / ANWEISUNGEN / INSTRUCTIONS / ISTRUZIONI

# BRABURA

GRILLS

**08**

Step  
Paso  
Schritt  
Étape  
Passo

**LITE Series 300**  
Flank N4 + R-Base  
Flank N4 + Fridge Rear

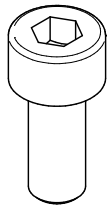

COMPONENT	QUANTITY
SCREW M5x10	7

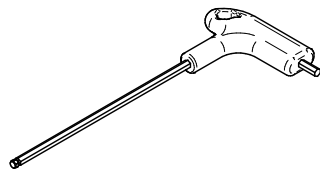

TOOLS REQUIRED
ALLEN WRENCH

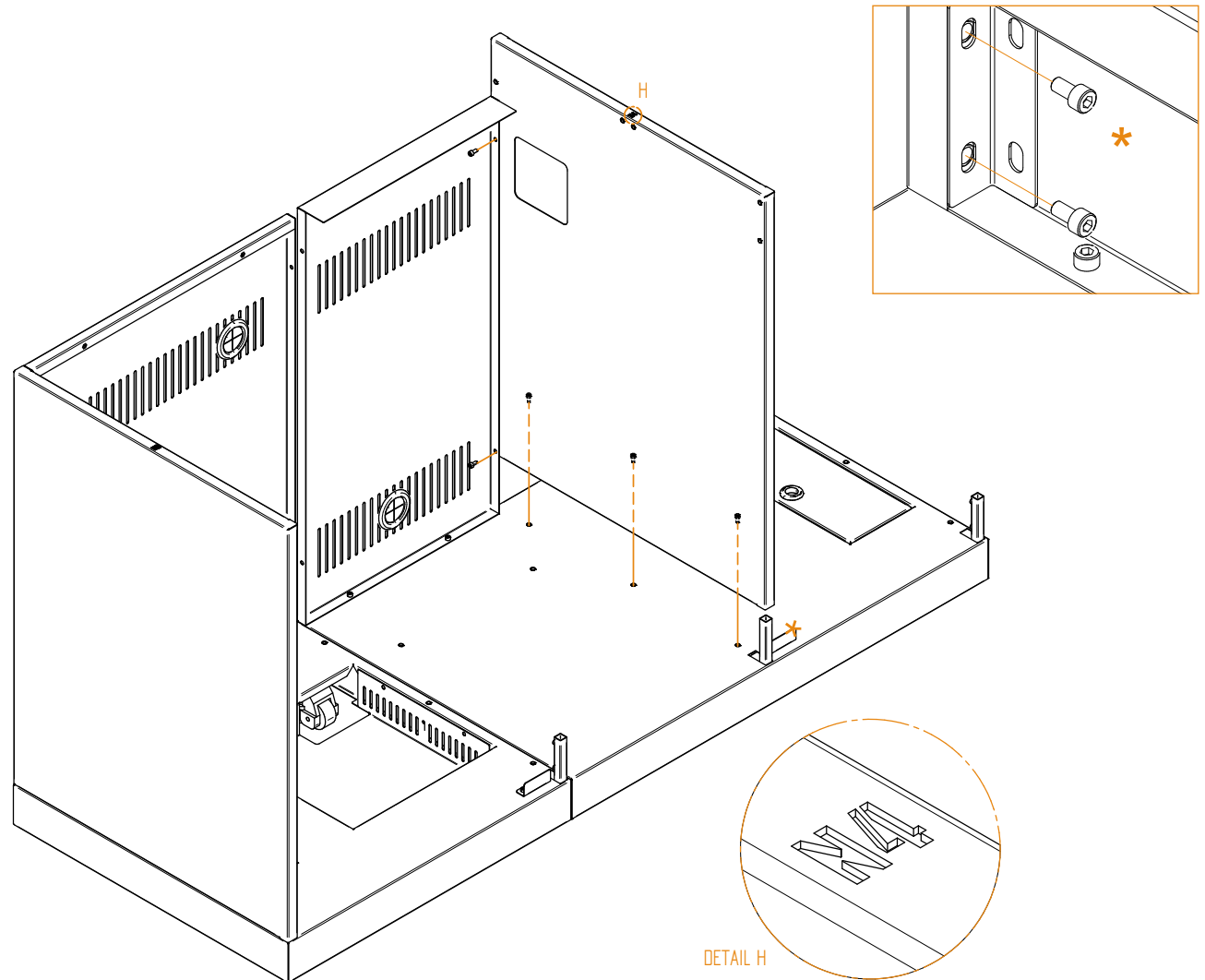

# INSTRUCTIONS

INSTRUCCIONES / ANWEISUNGEN / INSTRUCTIONS / ISTRUZIONI

# BRABURA

GRILLS

**09**

Step  
Paso  
Schritt  
Étape  
Passo

**LITE Series 300**  
Sink Rear + R-Base  
Sink Rear + Flank N4  
Register Top + Sink Rear

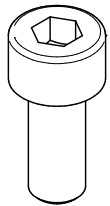

COMPONENT	QUANTITY
SCREW M5x10	8

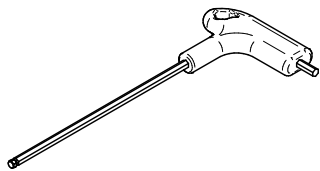

TOOLS REQUIRED
ALLEN WRENCH

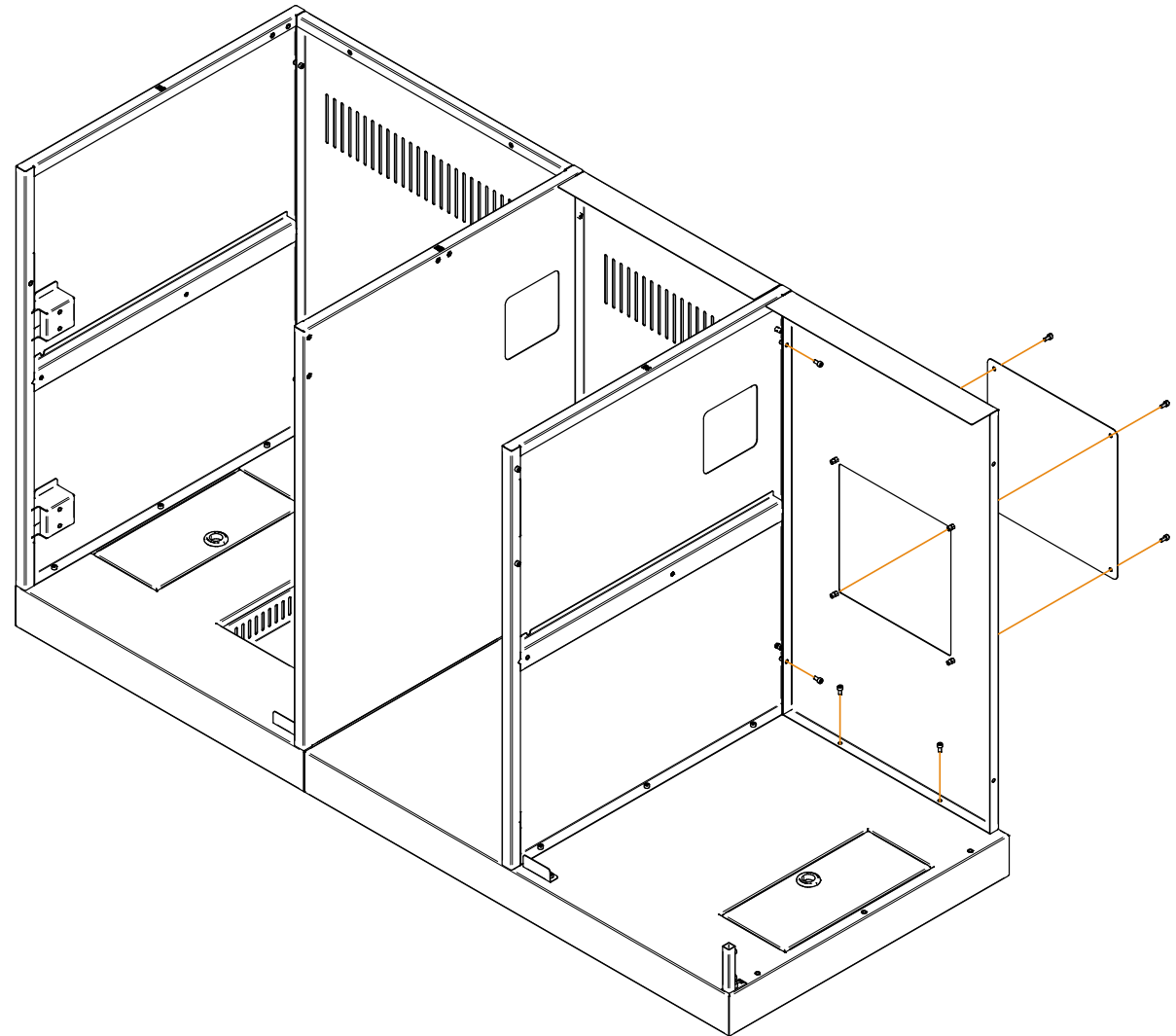

# INSTRUCTIONS

INSTRUCCIONES / ANWEISUNGEN / INSTRUCTIONS / ISTRUZIONI

# BRABURA

GRILLS

**10**

Step  
Paso  
Schritt  
Étape  
Passo

**LITE Series 300**  
Flank N5 + R-Base  
Flank N5 + Sink Rear

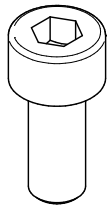

COMPONENT	QUANTITY
SCREW M5x10	7

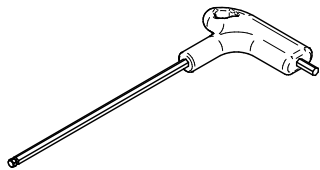

TOOLS REQUIRED
ALLEN WRENCH

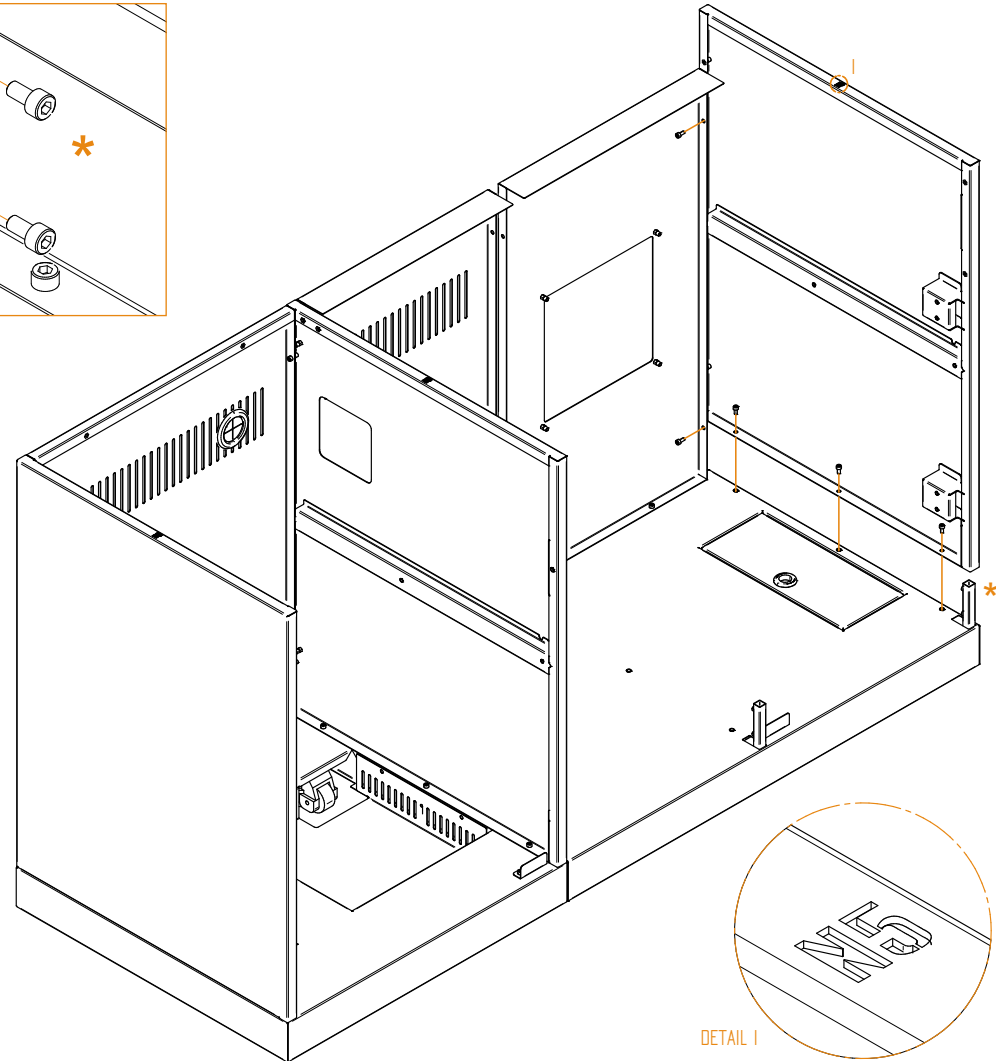
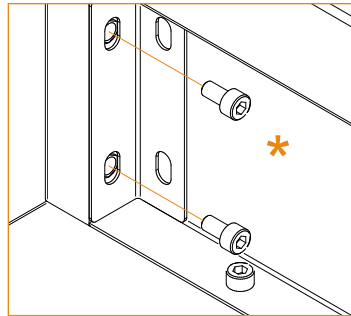

# INSTRUCTIONS

INSTRUCCIONES / ANWEISUNGEN / INSTRUCTIONS / ISTRUZIONI

# BRABURA

GRILLS

**11**

**Step**  
**Paso**  
**Schritt**  
**Étape**  
**Passo**

**LITE Series 300**  
Bottle Opener + Sink Rib  
Magnet + Sink Rib  
Magnet (2) + Grill Rib

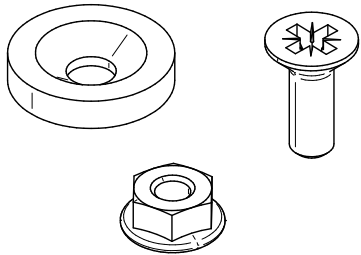

COMPONENTS	QUANTITY
COUNTERSUNK SCREW M4x10	2
MAGNET	2
M4 NUT	6

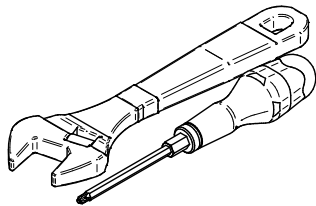

TOOLS REQUIRED
ADJUSTABLE WRENCH
SCREWDRIVER PHILLIPS-TIP

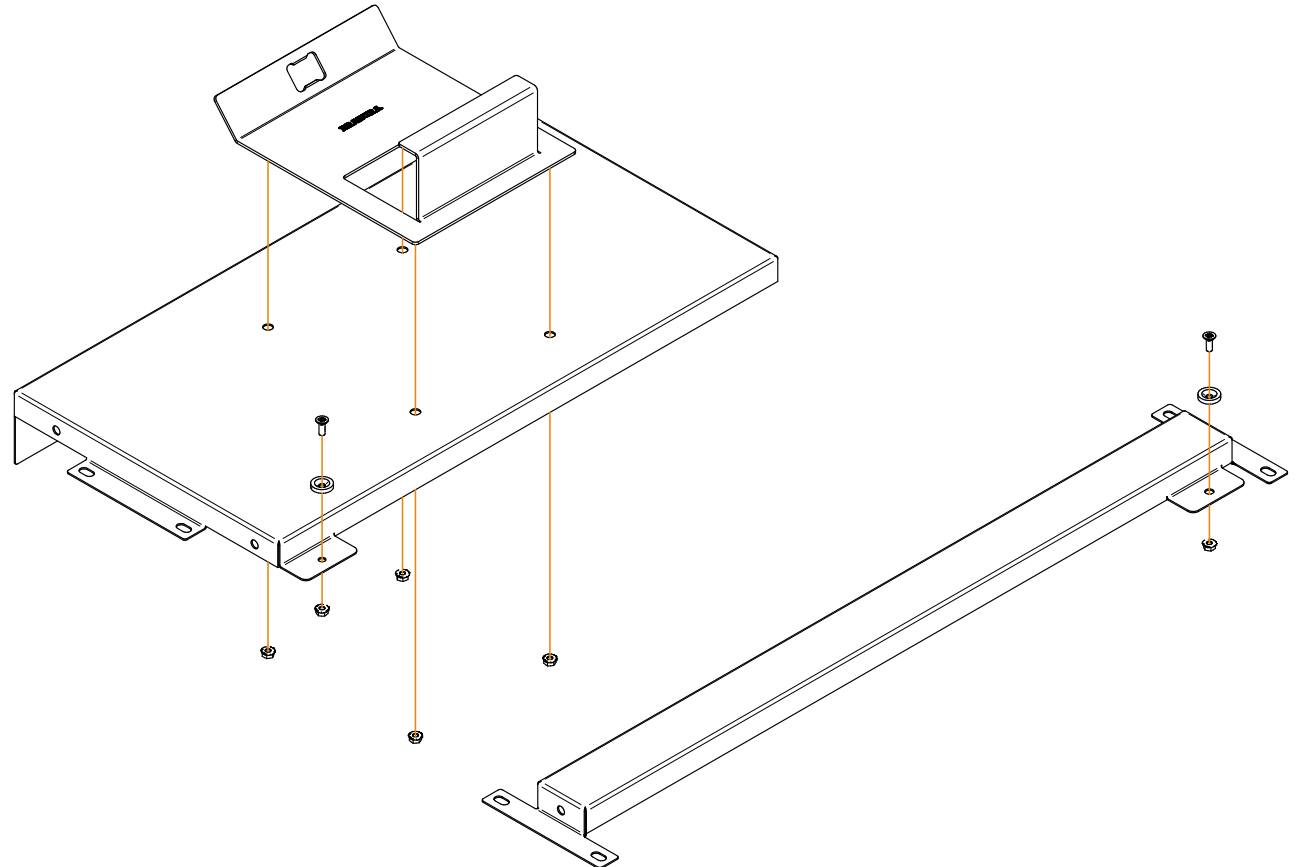

# INSTRUCTIONS

INSTRUCCIONES / ANWEISUNGEN / INSTRUCTIONS / ISTRUZIONI

# BRABURA

GRILLS

12

Step  
Paso  
Schritt  
Étape  
Passo

**LITE Series 300**  
Grill Rib + Flank N6  
Grill Rib + Flank N3  
Fridge Rib + Flank N3  
Fridge Rib + Flank N4  
Sink Rib + Flank N4  
Sink Rib + Flank N5

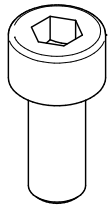

COMPONENT	QUANTITY
SCREW M5x10	18

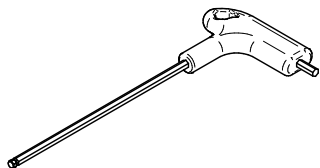

TOOLS REQUIRED
ALLEN WRENCH

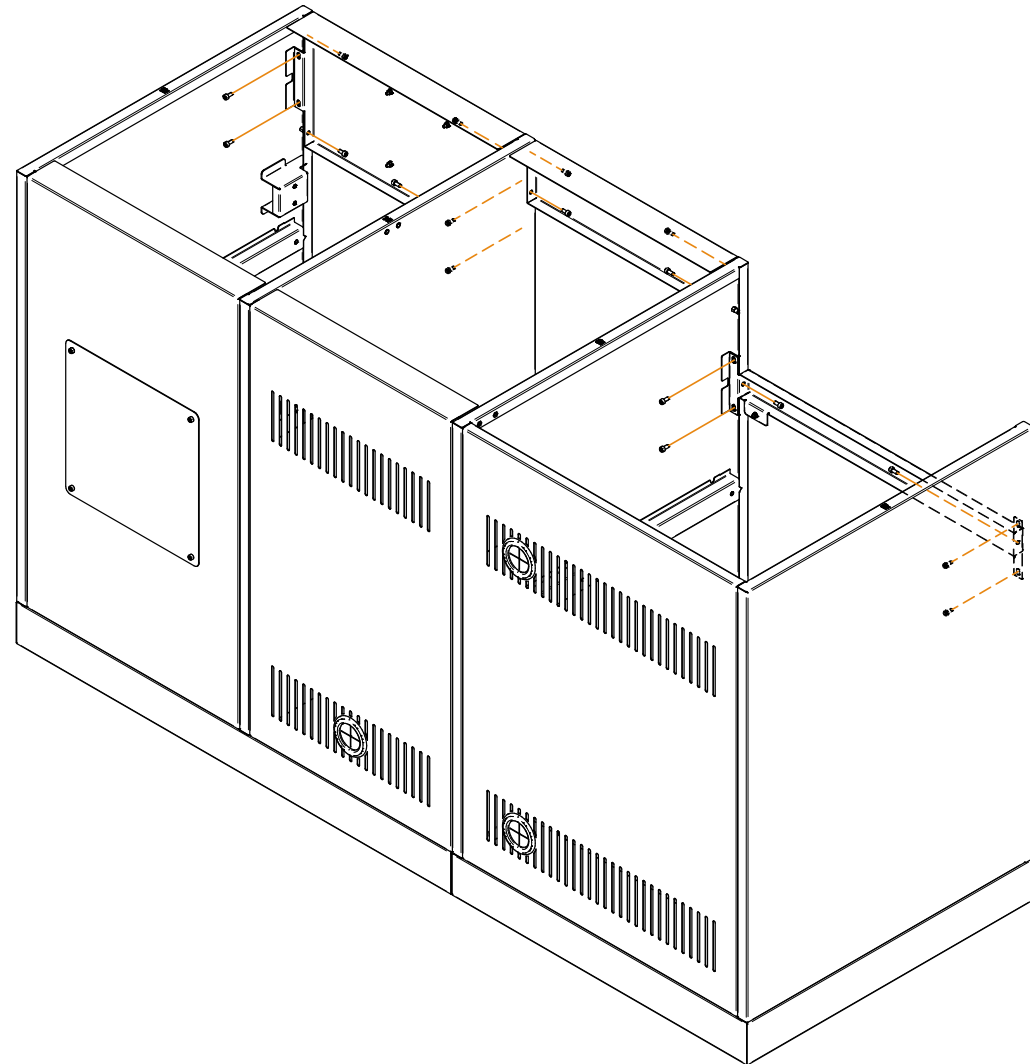

# INSTRUCTIONS

INSTRUCCIONES / ANWEISUNGEN / INSTRUCTIONS / ISTRUZIONI

# BRABURA

GRILLS

**13**

Step  
Paso  
Schritt  
Étape  
Passo

## LITE Series 300

Grill Stone Support + Flank N6  
Grill Stone Support + Flank N3  
Grill Stone Support + Grill Rear  
Fridge Stone Support + Flank N3  
Fridge Stone Support + Flank N4

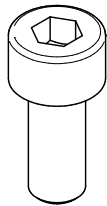

COMPONENT	QUANTITY
SCREW M5x10	10

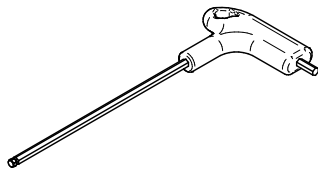

TOOLS REQUIRED
ALLEN WRENCH

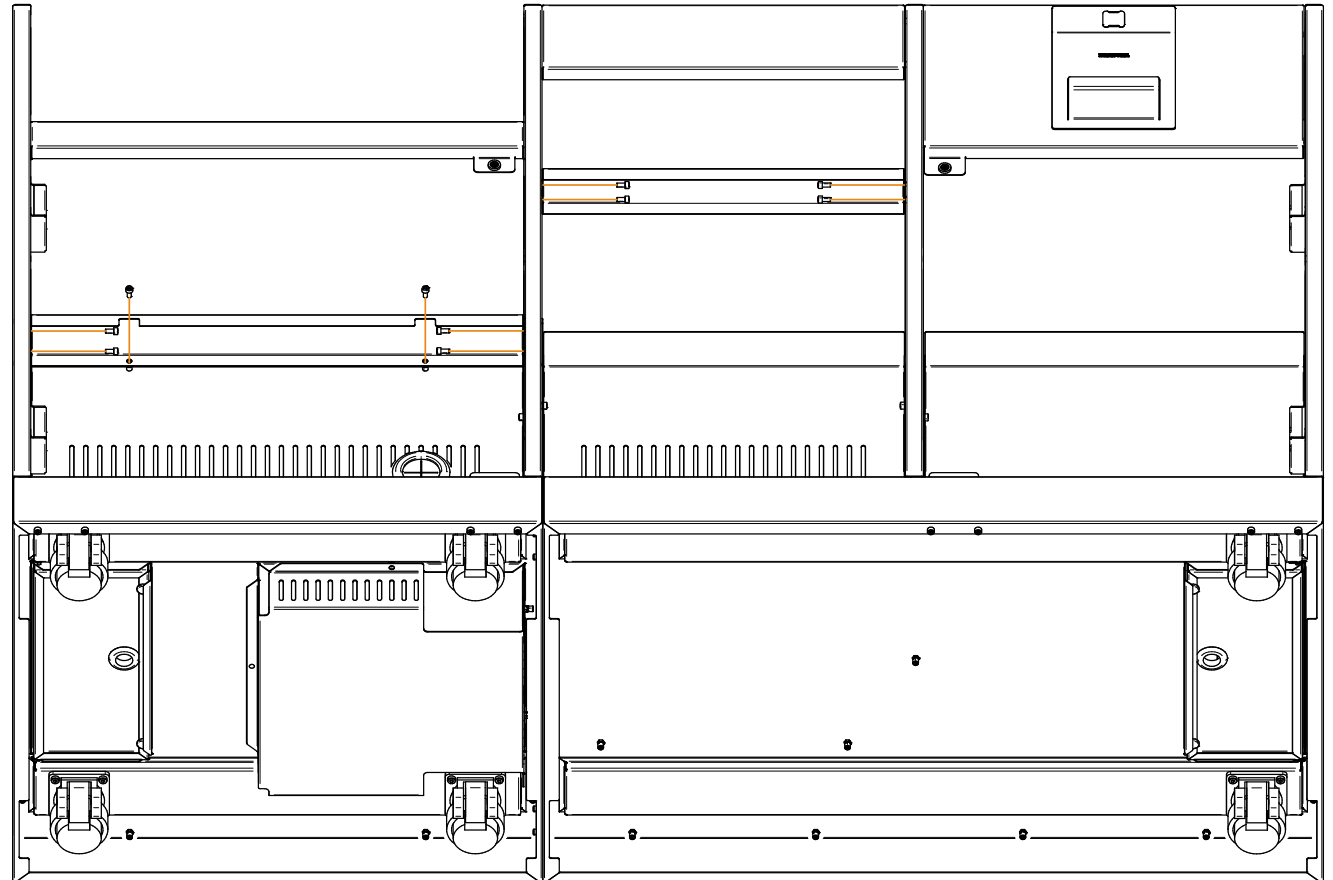

# INSTRUCTIONS

INSTRUCCIONES / ANWEISUNGEN / INSTRUCTIONS / ISTRUZIONI

# BRABURA

GRILLS

14

Step  
Paso  
Schritt  
Étape  
Passo

## LITE Series 300

Bin Frame + Bin Door

Handle + Bin Door

Paper-Towel Support + Door

Handle + Door

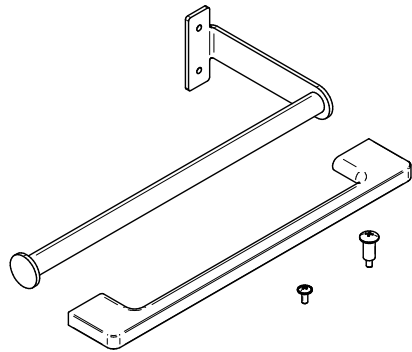

COMPONENTS	QUANTITY
PAPER-TOWEL SUPPORT	1
HANDLE	3
ROUNDHEAD SCREW 8x16 M4x7	6
ROUNDHEAD SCREW M4x10	6

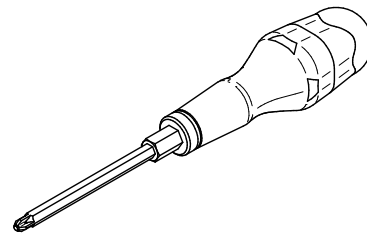

### TOOLS REQUIRED

SCREWDRIVER PHILLIPS-TIP

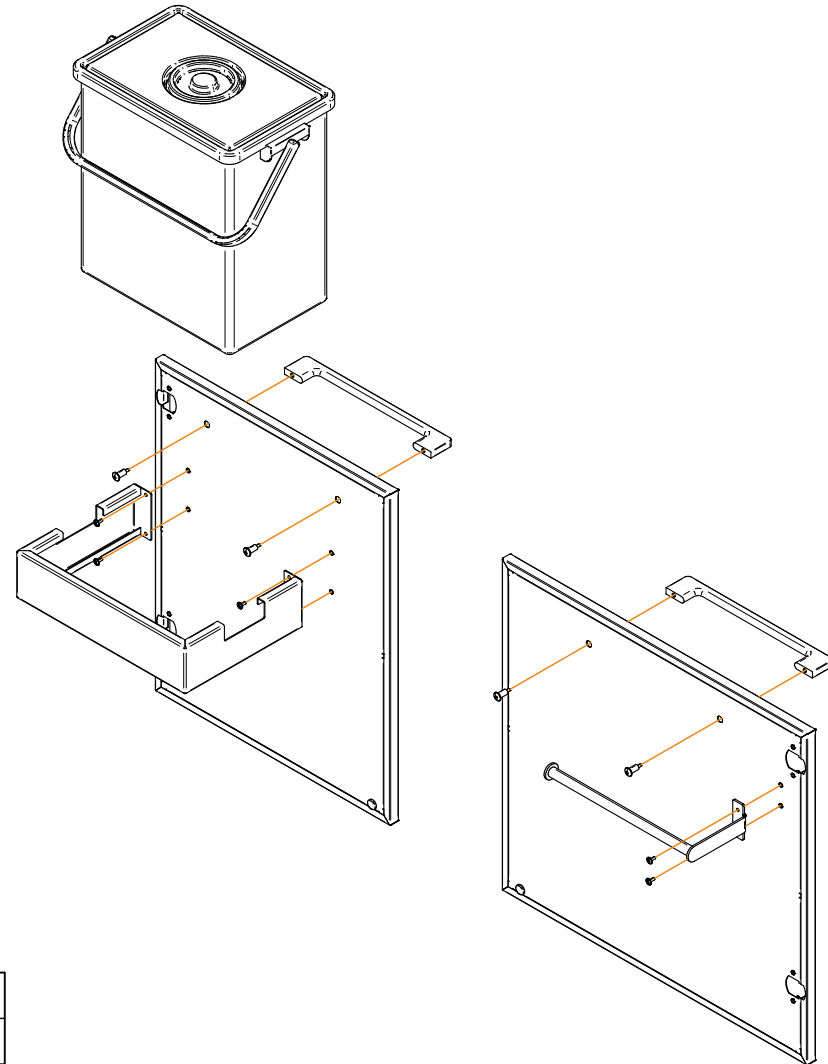

# INSTRUCTIONS

INSTRUCCIONES / ANWEISUNGEN / INSTRUCTIONS / ISTRUZIONI

# BRABURA

GRILLS

**15**

**Step** LITE Series 300  
**Paso** Hinge (2) + Flank N2  
**Schritt** Hinge (2) + Door  
**Étape** Hinge (2) + Flank N5  
**Passo** Hinge (2) + Bin Door

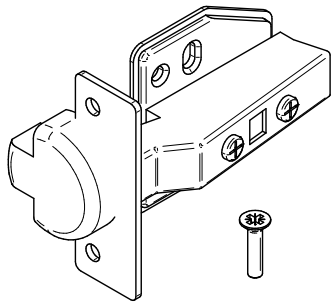

COMPONENTS	QUANTITY
HINGE	4
COUNTERSUNK SCREW M4x16	16

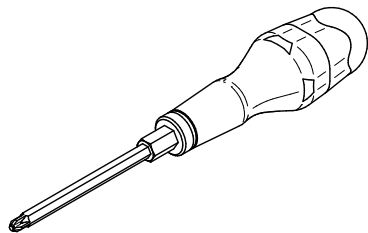

TOOLS REQUIRED
SCREWDRIVER PHILLIPS-TIP

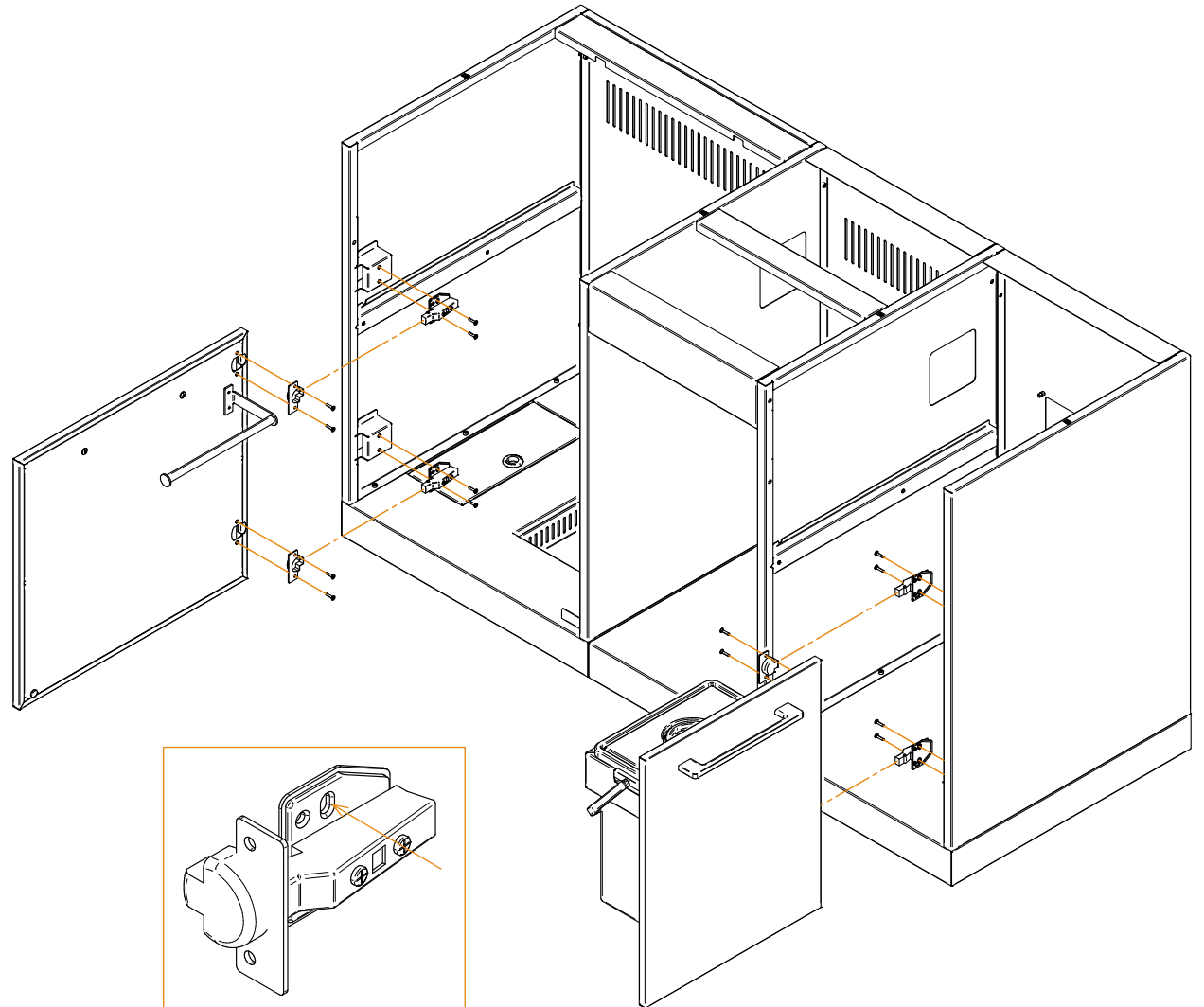

# INSTRUCTIONS

INSTRUCCIONES / ANWEISUNGEN / INSTRUCTIONS / ISTRUZIONI

# BRABURA

GRILLS

**EN Sink Installation**  
Fix the sink to the inferior face of the Neolith stone. Use a suitable adhesive for kitchen countertops and stainless steel, and wait at least 2 hours of drying time before turning the countertop.

**ES Instalación del Fregadero**  
Fije el fregadero a la cara inferior de la piedra Neolith. Use un adhesivo adecuado para encimeras de cocina y acero inoxidable, y espere un mínimo de 2 h de secado hasta voltear la encimera

**DE Spülbeckeninstallation**  
Befestigen Sie das Spülbecken an der Unterseite des Neolith-Steins. Verwenden Sie einen geeigneten Klebstoff für Küchenarbeitsplatten und Edelstahl. Warten Sie mindestens 2 Stunden Trocknungszeit, bevor Sie die Arbeitsplatte umdrehen.

**FR Installation de l'Évier**  
Fixez l'évier à la face inférieure de la pierre Neolith. Utilisez un adhésif adapté aux plans de travail de cuisine et à l'acier inoxydable et attendez au moins 2 heures de séchage avant de retourner le plan de travail.

**IT Installazione del Lavandino**  
Fissa il lavandino alla faccia inferiore della pietra Neolith. Utilizzare un adesivo adatto per piani cucina e acciaio inossidabile. Attendere almeno 2 ore di asciugatura prima di capovolgere il piano di lavoro.

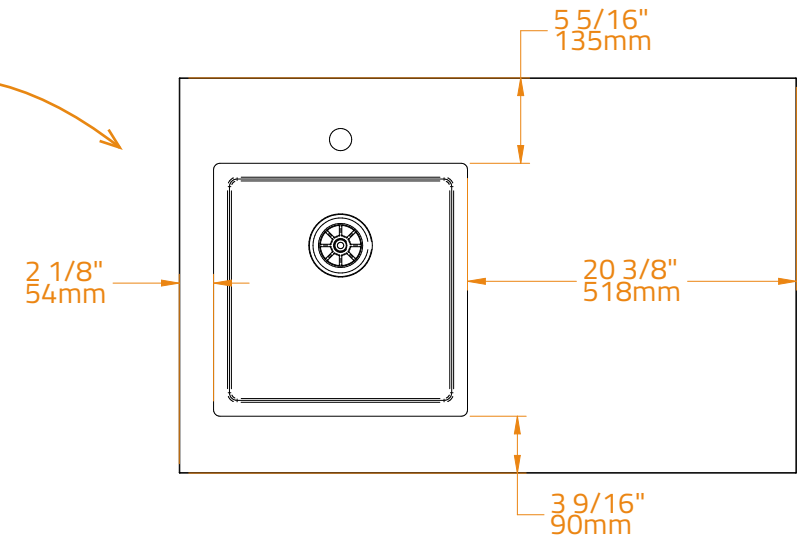
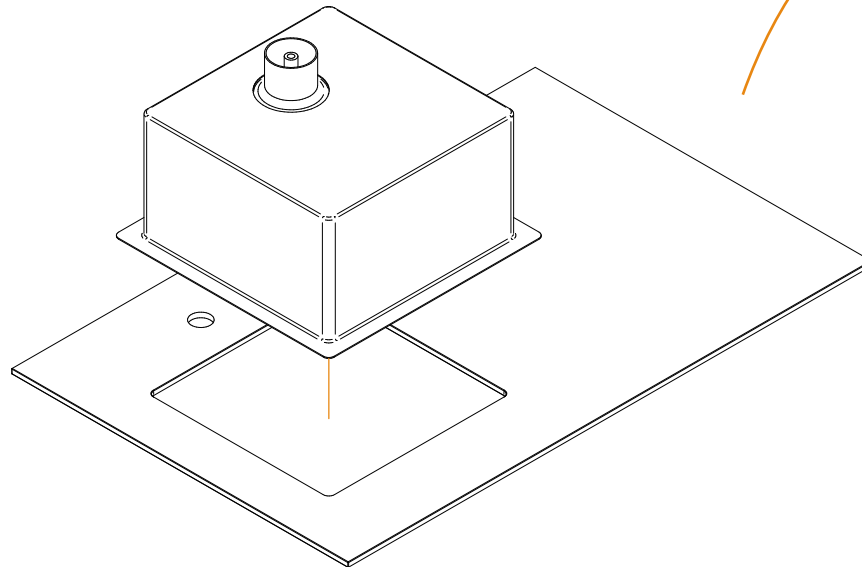

# INSTRUCTIONS

INSTRUCCIONES / ANWEISUNGEN / INSTRUCTIONS / ISTRUZIONI

**BRABURA**  
GRILLS

## EN Stone Installation

1. Stick the stone to the countertop plate using adequate adhesive to fix the stone in its place.
2. Remove any excess of adhesive using a damp cloth.

**RECOMENDATION:** When the outdoor kitchen is already mounted and positioned, BRABURA Grills recommends to seal the seams between stones with outdoor suitable adhesive for best performance and results.

## ES Instalación de la Piedra

1. Adhiera la piedra a la placa de la encimera utilizando un adhesivo adecuado para fijar la piedra en su lugar.
2. Elimine cualquier exceso de adhesivo utilizando un paño húmedo.

**RECOMENDACIÓN:** Cuando la cocina exterior ya esté montada y posicionada, BRABURA Grills recomienda sellar las juntas entre las piedras con un adhesivo adecuado para exteriores para obtener el mejor rendimiento y resultados.

## DE Einbau von Stein

1. Befestigen Sie den Stein mit einem geeigneten Kleber auf der Arbeitsplatte, um den Stein an Ort und Stelle zu fixieren.
2. Entfernen Sie überschüssigen Kleber mit einem feuchten Tuch.

**EMPFEHLUNG:** Wenn die Außenküche bereits montiert und positioniert ist, empfiehlt BRABURA Grills, die Fugen zwischen den Steinen mit einem geeigneten Außenkleber zu versiegeln, um die beste Leistung und Ergebnisse zu erzielen.

## FR Installation de la Pierre

1. Collez la pierre sur le dessus du plan de travail à l'aide d'un adhésif approprié pour fixer la pierre en place.
2. Éliminez tout excès d'adhésif à l'aide d'un chiffon humide.

**RECOMMANDATION :** Lorsque la cuisine extérieure est déjà montée et positionnée, BRABURA Grills recommande de sceller les joints entre les pierres avec un adhésif approprié pour l'extérieur afin d'obtenir les meilleurs performances et résultats.

## IT Installazione della Pietra

1. Incollare la pietra sulla parte superiore del piano di lavoro utilizzando un adesivo adatto per fissare la pietra al suo posto.
2. Eliminare eventuali eccessi di adesivo con un panno umido.

**RACCOMANDAZIONE:** Quando la cucina esterna è già montata e posizionata, BRABURA Grills consiglia di sigillare le giunture tra le pietre con un adesivo appropriato per esterni al fine di ottenere le migliori prestazioni e risultati.

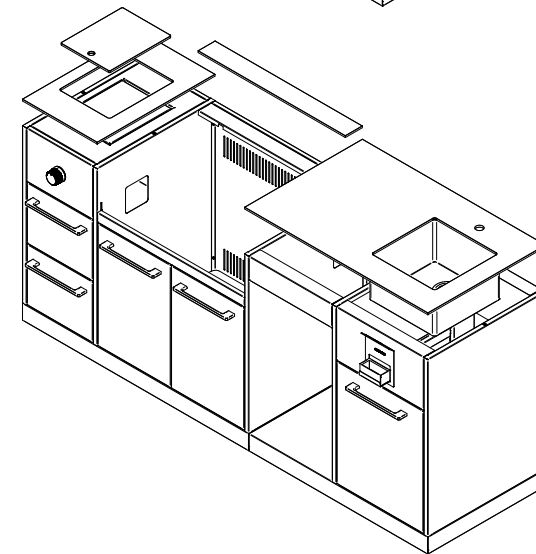
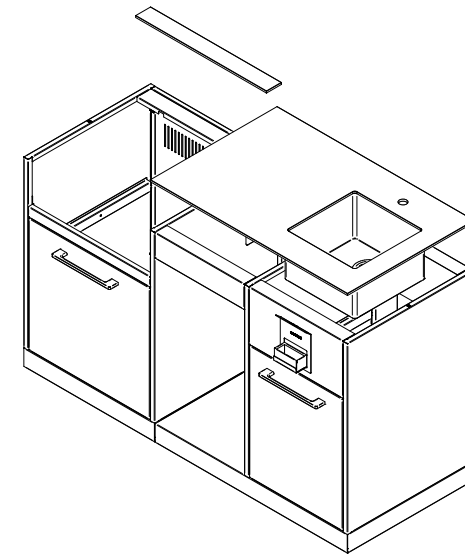

# INSTRUCTIONS

INSTRUCCIONES / ANWEISUNGEN / INSTRUCTIONS / ISTRUZIONI

# BRABURA

GRILLS

EN

## Grill, Fridge and Faucet

Position the Fusion LITE 400 or Fusion LITE 300, the Brabura Fridge, and install the faucet in their respective locations. BRABURA recommends using a layer of protective foam on the kitchen base to place the fridge in its position, and removing it afterwards to avoid damaging the kitchen base.

ES

## Barbacoa, Frigorífico y Grifo

Coloque la Fusion LITE 400 o Fusion LITE 300, el frigorífico Brabura y monte el grifo en sus posiciones correspondientes. BRABURA recomienda utilizar una capa de foam protector en la base de la cocina para colocar el frigo en su posición, y retirar posteriormente para no dañar la base.

DE

## Grill, Kühlschrank und Wasserhahn

Positionieren Sie die Fusion LITE 400 oder Fusion LITE 300, den Brabura-Kühlschrank, und montieren Sie den Wasserhahn an den vorgesehenen Stellen. BRABURA empfiehlt, eine Schicht Schutzschaum auf der Küchenbasis zu verwenden, um den Kühlschrank in seine Position zu bringen, und sie anschließend zu entfernen, um die Küchenbasis nicht zu beschädigen.

FR

## Gril, Réfrigérateur et Robinet

Placez la Fusion LITE 400 ou Fusion LITE 300, le réfrigérateur Brabura et installez le robinet à leurs emplacements respectifs. BRABURA recommande d'utiliser une couche de mousse protectrice sur la base de la cuisine pour placer le réfrigérateur dans sa position, puis de l'enlever ensuite afin de ne pas endommager la base

IT

## Griglia, Frigorifero e Rubinetto

Posizionare la Fusion LITE 400 o Fusion LITE 300, il frigorifero Brabura e montare il rubinetto nelle rispettive posizioni. BRABURA consiglia di utilizzare uno strato di foam protettivo sulla base della cucina per posizionare il frigorifero e di rimuoverlo successivamente per evitare di danneggiare la base della cucina.

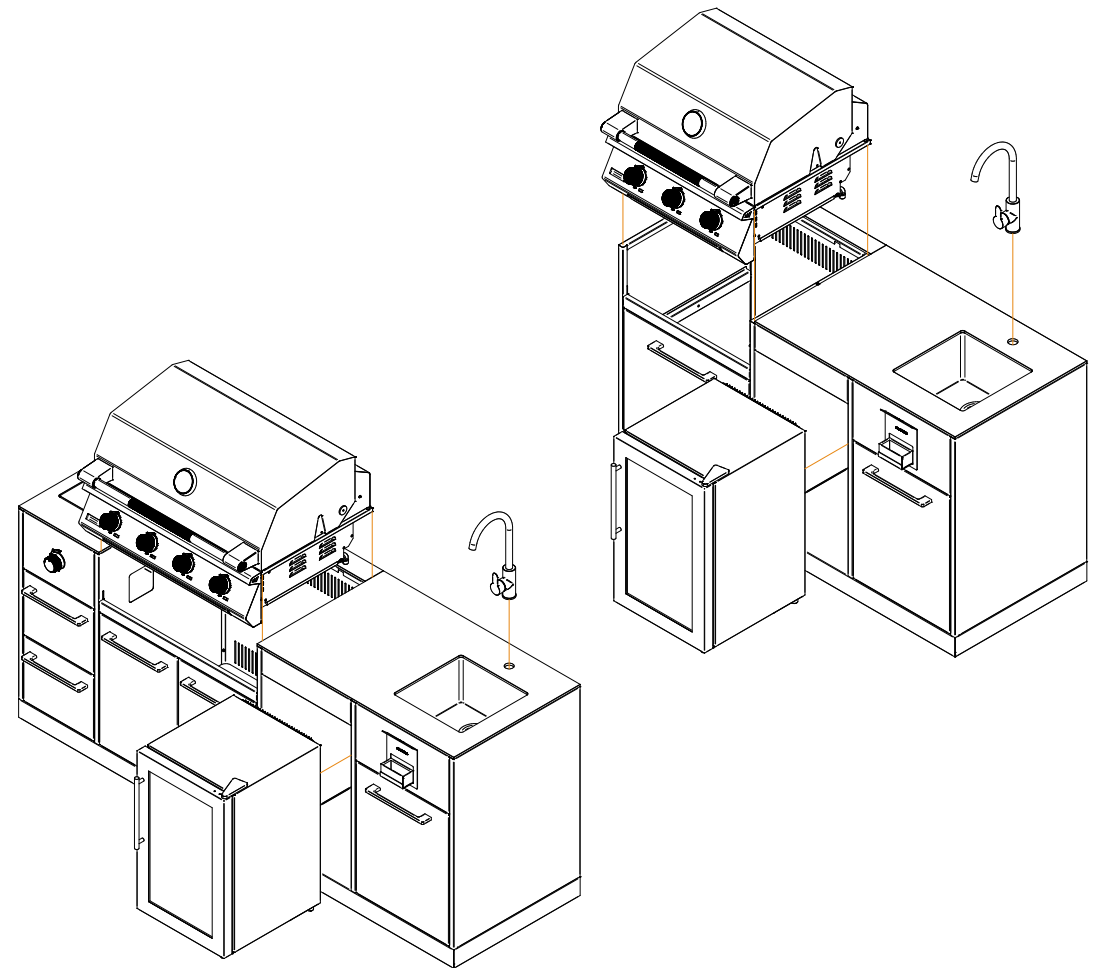

# INSTRUCTIONS

INSTRUCCIONES / ANWEISUNGEN / INSTRUCTIONS / ISTRUZIONI

**BRABURA**  
GRILLS

- EN Faucet Installation**  
Faucet is always received uninstalled and it is necessary to do the installation. In case an exclusive water pipework is not going to be installed, LITE Series kitchens include a "T" attachment to connect it to an existing outdoor hose water outlet. Follow the steps in the image for a proper installation.  
**NOTE:** Washers code: R (Round), B (Black), W (White).

- ES Instalación del Grifo**  
El grifo siempre se recibe sin instalar, y es necesario realizar la instalación. En caso de que no se vaya a realizar una instalación de agua exclusiva, las cocinas LITE Series incluye un accesorio en T para conectarlo a una toma de manguera exterior ya existente. Siga los pasos en la imagen para una instalación adecuada.  
**NOTA:** Códigos de arandelas: R (Redonda), B (Negra), W (Blanca).

- DE Einbau der Armatur**  
Der Wasserhahn wird immer unmontiert geliefert, und die Installation ist erforderlich. Wenn keine separate Wasserinstallation vorgesehen ist, enthalten die Küchen der LITE Series ein „T“-Verbindungsstück, um ihn an einen vorhandenen Außenwasseranschluss anzuschließen. Befolgen Sie die Schritte auf dem Bild für eine ordnungsgemäße Installation.  
**HINWEIS:** Arten der Unterlegscheiben: R (Rund), B (Schwarz), W (Weiß).

- FR Installation du Robinet**  
Le robinet est toujours livré non installé, et il est nécessaire de procéder à l'installation. Si une installation d'eau exclusive n'est pas prévue, les cuisines LITE Series incluent un raccord en « T » pour le connecter à une sortie de tuyau d'eau extérieure existante. Suivez les étapes de l'image pour une installation correcte.  
**NOTE:** Codes des rondelles : R (Ronde), B (Noire), W (Blanche).

- IT Installazione del Rubinetto**  
Il rubinetto viene sempre fornito non installato ed è necessario procedere con l'installazione. Se non si prevede un impianto idrico dedicato, le cucine "LITE Series" includono un raccordo a "T" per collegarlo a un'uscita dell'acqua esterna esistente. Seguire i passaggi nell'immagine per un'installazione corretta.  
**NOTA:** Codici delle guarnizioni: R (Rossa), B (Nera), W (Bianca).

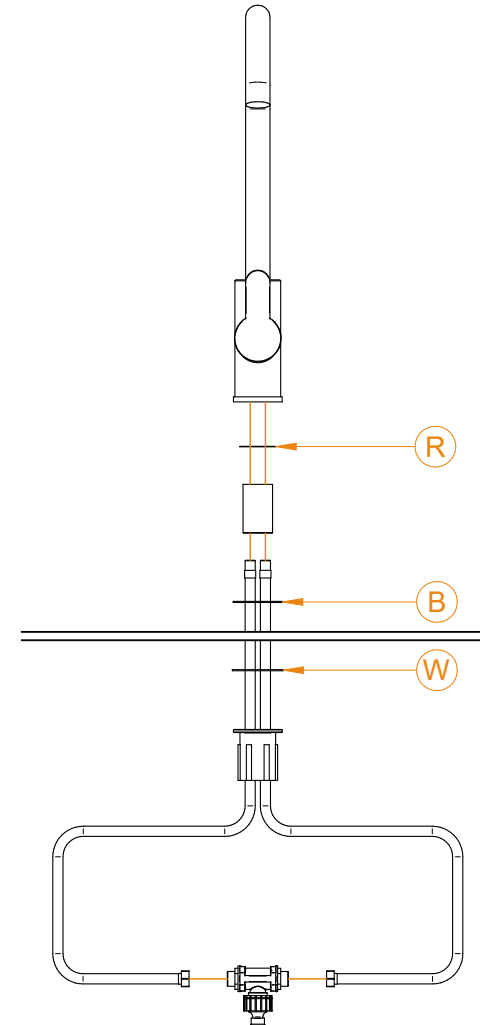

# INSTRUCTIONS

INSTRUCCIONES / ANWEISUNGEN / INSTRUCTIONS / ISTRUZIONI

**BRABURA**  
GRILLS

**EN Leg Adjustment Screw**  
At the base of LITE Series kitchens, access panels lead to the adjustable legs. Turn the central screw to level the kitchen. Raise the legs fully to engage the wheels and move the unit easily.

**ES Rosca de Ajuste de las Patas**  
En la base de las cocinas LITE Series hay compuertas de acceso a las patas regulables. Ajuste la altura girando la rosca central hasta nivelar la cocina. Puede elevar completamente las patas para activar las ruedas y mover la cocina con facilidad.

**DE Einstellschraube für Beine**  
An der Basis der LITE Series-Küchen befinden sich Klappen zu den verstellbaren Füßen. Drehen Sie die mittlere Schraube, um die Küche auszurichten. Heben Sie die Füße vollständig an, um die Räder zu aktivieren und die Küche leicht zu bewegen.

**FR Vis de Réglage de Pied**  
À la base des cuisines LITE Series, des trappes donnent accès aux pieds réglables. Tournez la vis centrale pour mettre la cuisine à niveau. Relevez complètement les pieds pour activer les roues et déplacer facilement l'unité.

**IT Vite di Regolazione delle Gambe**  
Alla base delle cucine LITE Series ci sono sportelli che permettono l'accesso ai piedini regolabili. Ruotare la vite centrale per livellare la cucina. Sollevare completamente i piedini per attivare le ruote e spostare facilmente l'unità.

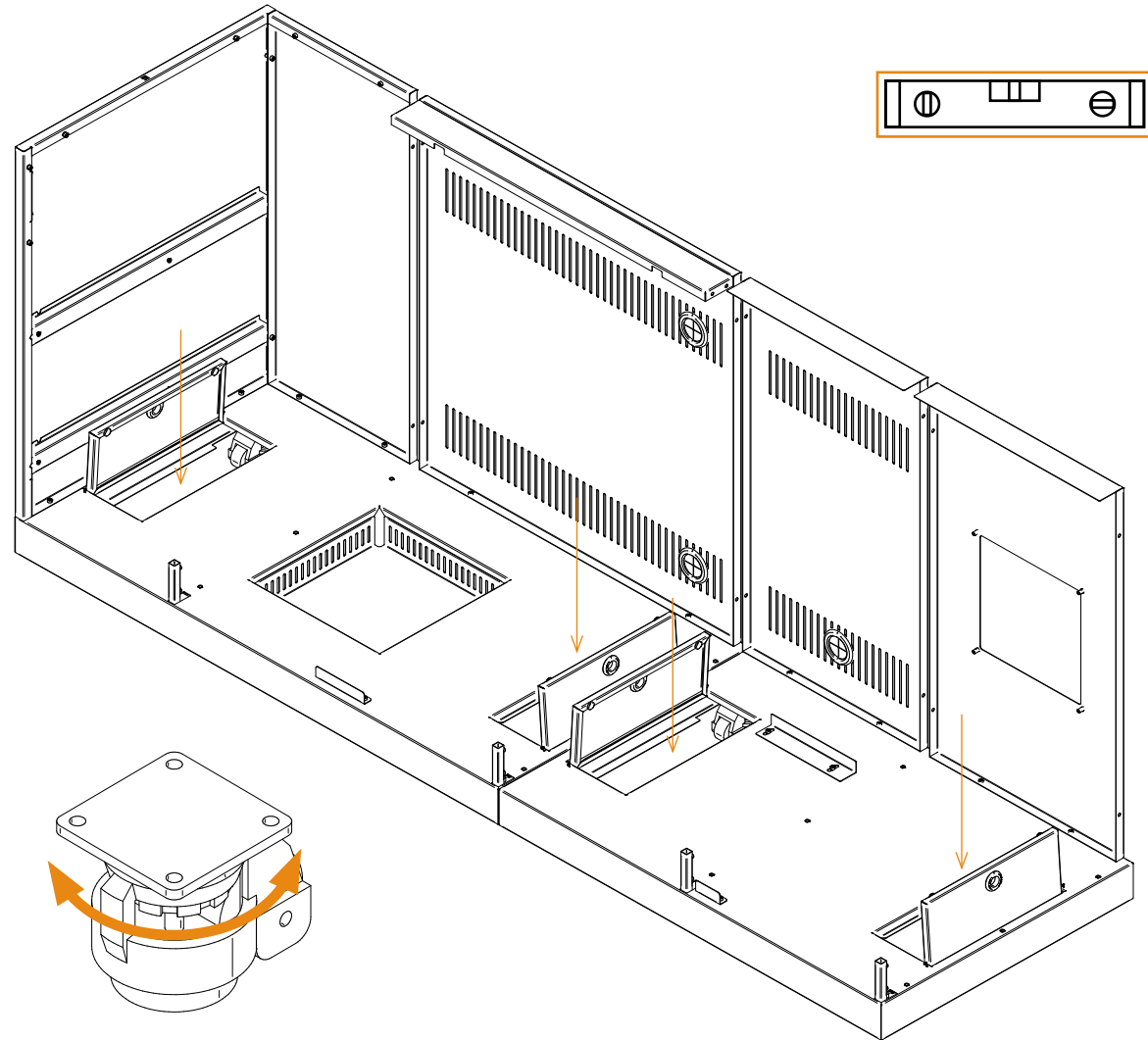

# INSTRUCTIONS

INSTRUCCIONES / ANWEISUNGEN / INSTRUCTIONS / ISTRUZIONI

**BRABURA**  
GRILLS

EN

## Gas Tank Placement

LITE Series kitchens feature a basket designed to hold the gas tank. The basket ensures that the tank remains stable and includes additional ventilation openings.

ES

## Colocación de Bombona de Gas

Las cocinas LITE Series cuentan con una cesta diseñada para colocar el tanque de gas. Esta cesta asegura que el tanque permanezca estable y dispone de aberturas adicionales para una correcta ventilación.

DE

## Platzierung der Gasflasche:

Die Elektrogerätemodule der BRABURA LITE Series kitchen verfügen über eine Ablage für Gasflaschen, auf der die Gasflasche platziert wird. Die Ablage kann für eine bequeme Nutzung herausgezogen werden, um die Gasflasche zu platzieren.

FR

## Placement de la bouteille de gaz

Les cuisines LITE Series sont équipées d'un panier conçu pour accueillir la bouteille de gaz. Ce panier maintient la bouteille en place et comprend des ouvertures supplémentaires pour une ventilation adéquate.

IT

## Posizionamento della Bombola del Gas

Die LITE Series Küchen verfügen über einen Korb zur Aufnahme der Gasflasche. Der Korb sorgt dafür, dass die Flasche stabil bleibt, und verfügt über zusätzliche Belüftungsöffnungen.

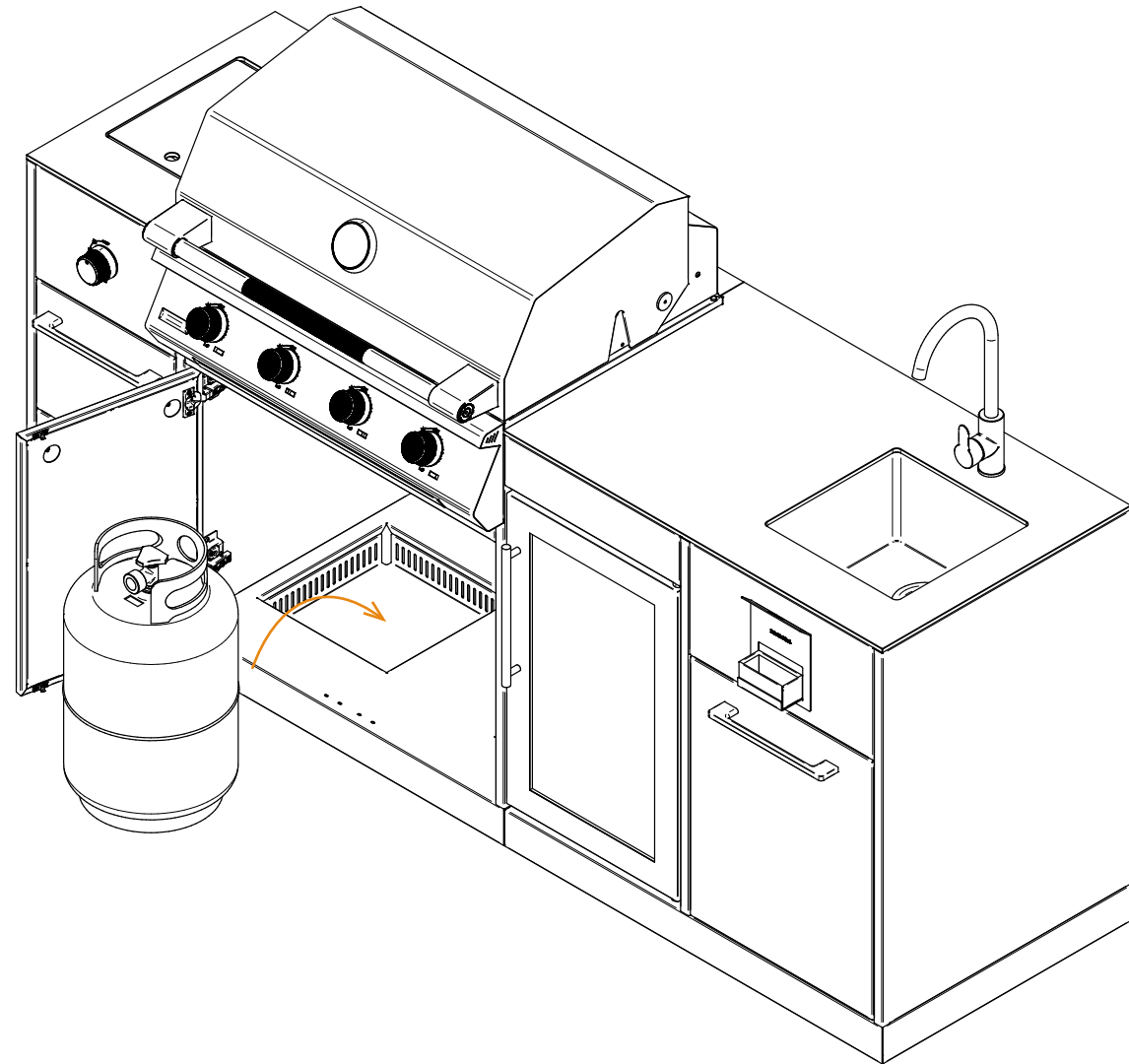

# GAS CONNECTIONS

CONEXIONES DE GAS / GASANSCHLÜSSE/ RACCORDEMENTS DE GAZ / COLLEGAMENTI DEL GAS

**BRABURA**  
GRILLS

## EN "Y" Gas Connection for Fusion Lite and Side Burner

The gas connection is made using a "Y" fitting that distributes gas from the cylinder to the Fusion LITE and Side Burner. The inlet of the "Y" fitting connects to the gas cylinder valve, while each outlet is joined to the units using corrugated metal hoses. All connections must be secure and leak-free before opening the gas valve.

## ES Conexión de gas en "Y" para Fusion LITE y Side Burner

La conexión de gas se realiza mediante una pieza en "Y" que distribuye el gas desde la bombona hacia la Fusion LITE y el Side Burner. La entrada de la "Y" se conecta a la válvula de la bombona, mientras que cada salida se une mediante tuberías corrugadas metálicas a cada equipo. Todas las uniones deben quedar firmes y sin fugas antes de abrir la válvula de gas.

## DE „Y“-Gasanschluss für Fusion LITE und Side Burner

Die Gasverbindung erfolgt über ein „Y“-Verbindungsstück, das das Gas von der Flasche zur Fusion LITE und zum Side Burner verteilt. Der Eingang des „Y“-Stücks wird an das Ventil der Gasflasche angeschlossen, während jede Seite über flexible Metallrohre mit den Geräten verbunden ist. Alle Verbindungen müssen fest und dicht sein, bevor das Gasventil geöffnet wird.

## FR Raccordement de gaz en « Y » pour Fusion LITE et Side Burner

Le raccordement du gaz se fait à l'aide d'un raccord en « Y » qui distribue le gaz depuis la bouteille vers la Fusion LITE et le Side Burner. L'entrée du raccord « Y » se connecte à la vanne de la bouteille, tandis que chaque sortie est reliée aux appareils par des tuyaux métalliques flexibles. Toutes les connexions doivent être bien serrées et sans fuite avant d'ouvrir la vanne de gaz.

## IT Collegamento del gas a "Y" per Fusion LITE e Side Burner

Il collegamento del gas avviene tramite un raccordo a "Y" che distribuisce il gas dalla bombola alla Fusion LITE e al Side Burner. L'ingresso del raccordo "Y" si collega alla valvola della bombola, mentre ogni uscita è collegata agli apparecchi tramite tubi metallici corrugati. Tutte le connessioni devono essere salde e prive di perdite prima di aprire la valvola del gas.

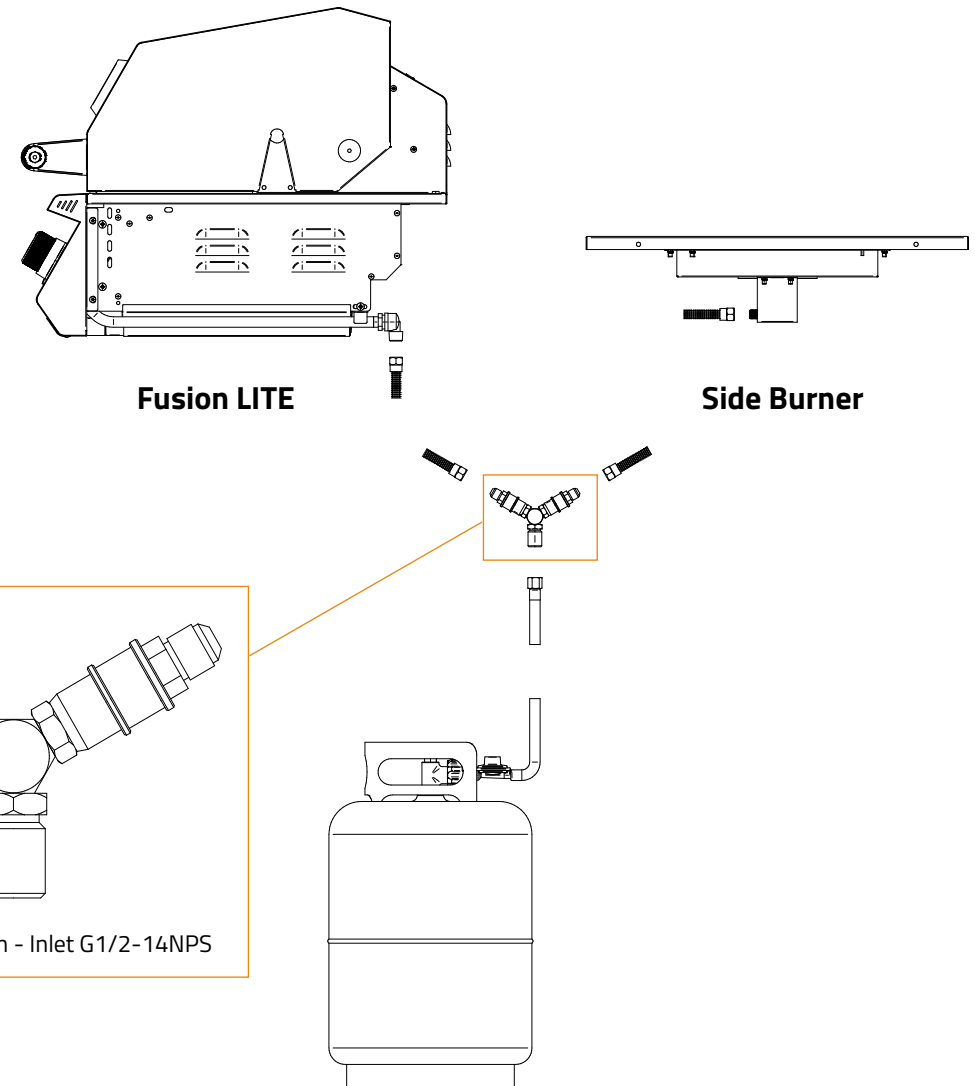

# GAS CONNECTIONS

CONEXIONES DE GAS / GASANSCHLÜSSE/ RACCORDEMENTS DE GAZ / COLLEGAMENTI DEL GAS

**BRABURA**  
GRILLS

## Leak Testing

1. Initial Check: All gas pipes and connections must be checked for leaks after installation, after any service, and before each use.
2. Check all valves, joints, connections, pipes, and every point from the gas source to the burners.
3. Ensure all control valves are in the "OFF" position before disconnecting or replacing the empty cylinder. If gas flow is low after the change, disconnect the regulator and reconnect it to restart.
4. Open the main valve or cylinder valve (ON position) and apply a soapy solution to all joints.
5. If bubbles form, there is a leak. Immediately shut off the supply and repair before use.
6. Make sure to include all valves, joints, and lines in the test before using the equipment.

## Test de fugas

1. Todas las tuberías y conexiones de gas deben revisarse en busca de fugas después de la instalación, después de cualquier servicio y antes de cada uso.
2. Compruebe todas las válvulas, uniones, conexiones, tuberías y cada punto desde la fuente de gas hasta los quemadores.
3. Antes de cambiar la bombona:  
Asegúrese de que todas las válvulas de control estén en posición "OFF" antes de desconectar o sustituir la bombona vacía. Si el flujo de gas es bajo después del cambio, desconecte el regulador y vuelva a conectarlo para reiniciarlo.
4. Abra la válvula de paso o la válvula de la bombona (posición ON) y aplique una solución jabonosa en todas las uniones.
5. Si se forman burbujas, hay una fuga. Cierre inmediatamente el suministro y repare antes de usar.
6. Asegúrese de incluir todas las válvulas, uniones y líneas en la prueba antes de utilizar el equipo.

## Prova di tenuta

1. Tutti i tubi e le connessioni del gas devono essere controllati per perdite dopo l'installazione, dopo qualsiasi intervento e prima di ogni utilizzo.
2. Controllare tutte le valvole, giunzioni, connessioni, tubazioni e ogni punto dalla fonte di gas ai bruciatori.
3. Assicurarsi che tutte le valvole di controllo siano in posizione "OFF" prima di staccare o sostituire la bombola vuota. Se il flusso di gas è basso dopo la sostituzione, staccare il regolatore e ricollegarlo per riavviarlo.
4. Aprire la valvola principale o la valvola della bombola (posizione ON) e applicare una soluzione saponosa su tutte le giunzioni.
5. Se si formano bolle, c'è una perdita. Chiudere immediatamente l'alimentazione e riparare prima dell'uso.
6. Assicurarsi di includere tutte le valvole, giunzioni e tubazioni nel test prima di utilizzare l'apparecchio.

## Test de fuites

1. Toutes les canalisations et connexions de gaz doivent être vérifiées pour détecter des fuites après l'installation, après tout entretien et avant chaque utilisation.
2. Vérifiez toutes les vannes, raccords, connexions, tuyaux et chaque point depuis la source de gaz jusqu'aux brûleurs.
3. Assurez-vous que toutes les vannes de contrôle sont en position "OFF" avant de déconnecter ou de remplacer la bouteille vide. Si le débit de gaz est faible après le changement, déconnectez le régulateur puis reconnectez-le pour le réinitialiser.
4. Ouvrez la vanne principale ou la vanne de la bouteille (position ON) et appliquez une solution savonneuse sur tous les raccords.
5. Si des bulles apparaissent, il y a une fuite. Coupez immédiatement l'alimentation et réparez avant utilisation.
6. Assurez-vous d'inclure toutes les vannes, raccords et conduites lors du test avant d'utiliser l'équipement.

## Dichtigkeitstest

1. Alle Gasleitungen und Verbindungen müssen nach der Installation, nach jedem Service und vor jeder Benutzung auf Undichtigkeiten überprüft werden.
2. Überprüfen Sie alle Ventile, Verbindungen, Anschlüsse, Rohre und jeden Punkt von der Gasquelle bis zu den Brennern.
3. Stellen Sie sicher, dass alle Steuerungen auf „OFF“ stehen, bevor Sie die leere Flasche trennen oder ersetzen. Wenn der Gasfluss nach dem Wechsel niedrig ist, trennen Sie den Regler und schließen Sie ihn wieder an, um ihn neu zu starten.
4. Öffnen Sie das Hauptventil oder das Flaschenventil (Position ON) und tragen Sie auf alle Verbindungen eine Seifenlösung auf.
5. Wenn Blasen entstehen, liegt ein Leck vor. Schalten Sie sofort die Versorgung ab und reparieren Sie es, bevor Sie das Gerät verwenden.
6. Stellen Sie sicher, dass alle Ventile, Verbindungen und Leitungen im Test enthalten sind, bevor Sie das Gerät verwenden.

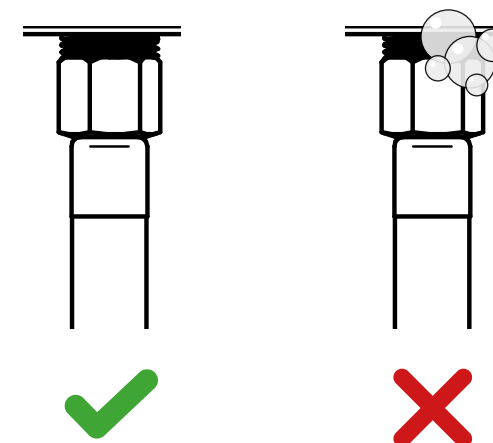

# ADJUSTMENT

REGULACIÓN / ANPASSUNG / AJUSTEMENT / REGOLAZIONE

**BRABURA**  
GRILLS

## EN Door Hinge Adjustment

The door hinges can be regulated by using a screwdriver. The screw located in the bearing of the hinge can be used to manually adjust height, the screw located near the cup is used for side adjustment and the one farthest from the cup is used to manually adjust depth.

## ES Ajuste de Bisagras

Las bisagras de la puerta se pueden ajustar utilizando un destornillador. El tornillo ubicado en el cojinete de la bisagra se utiliza para ajustar manualmente la altura, el tornillo ubicado cerca de la copa se utiliza para el ajuste lateral y el más alejado de la copa se utiliza para ajustar manualmente la profundidad.

## DE Türscharniereinstellung

Die Türscharniere können mit einem Schraubendreher eingestellt werden. Die Schraube im Scharnierlager dient zur manuellen Höheneinstellung, die Schraube in der Nähe der Topfaufnahme zur seitlichen Einstellung, und die am weitesten vom Topf entfernte Schraube zur manuellen Tiefeneinstellung.

## FR Réglage des charnières de porte

Les charnières de la porte peuvent être réglées à l'aide d'un tournevis. La vis située dans le pivot de la charnière permet d'ajuster manuellement la hauteur, celle placée près de la coupelle sert au réglage latéral, et celle la plus éloignée de la coupelle permet d'ajuster manuellement la profondeur.

## IT Regolazione delle Cerniere della Porta

Le cerniere della porta possono essere regolate utilizzando un cacciavite. La vite situata nel perno della cerniera serve per regolare manualmente l'altezza; quella vicino alla tazza serve per la regolazione laterale, e quella più lontana dalla tazza serve per regolare manualmente la profondità.

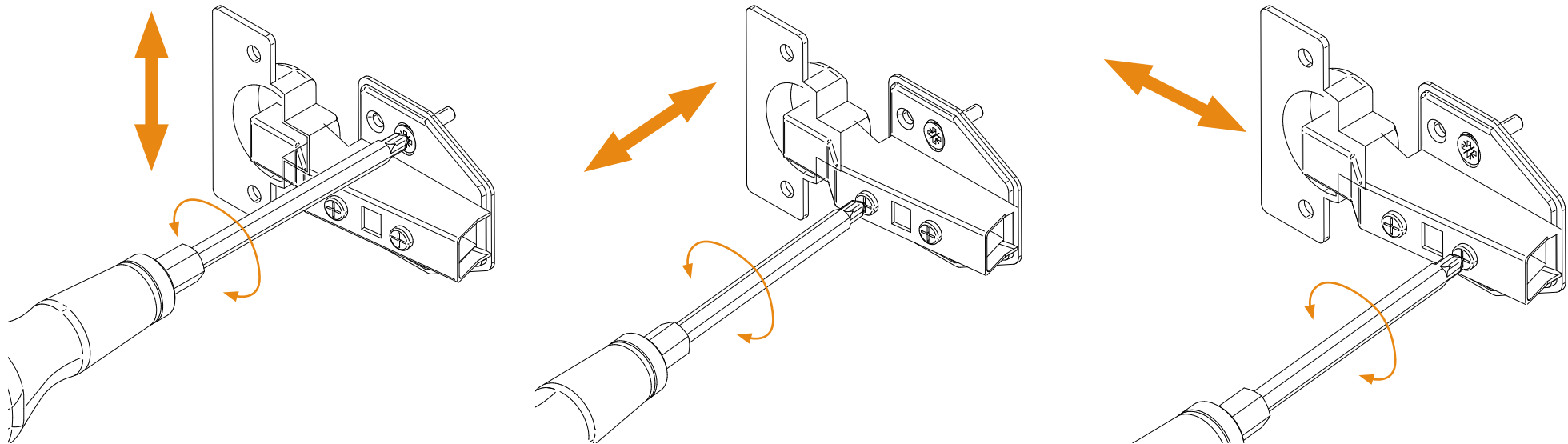

# CLEANING AND MAINTENANCE

**EN** To prolong the life of your BRABURA LITE Series please follow the recommended maintenance instructions:

## **Powder Coated Surfaces**

Scheduled cleaning will benefit and extend the long lasting aesthetics of the finish.

This procedure is an integral part of the warranty given for surface finish and color retention and it will minimize the weathering effect of dirt and other airborne pollutants which tend to accumulate on the surface of the coating, dulling its appearance. We suggest the following guidelines:

- Cleaning of the coated surfaces with warm water and mild detergent or non abrasive pH-banaced cleaner solution, and the use of non abrasive brush or sponge.
- The cleaning solution should not be allowed to be in contact with the powder coated surface for more than 30 minutes.
- DO NOT use any chlorides or quaternary salts on the module. DO NOT use any hydrochloric acid (muriatic acid) on modules. Refrain from using harsh chemicals, solvents, or abrasive cleaners, as they can damage the powder coating. Opt for cleaners specifically designed for powder-coated surfaces.
- After cleaning, the surface shall be completely rinsed-off with clean fresh water to remove any cleaning residue. This helps prevent the accumulation of cleaning agents that might affect the powder coating over time.
- A record of all cleaning schedules, frequencies and products should be kept and documented.
- While cleaning is crucial, avoid using high-pressure washers, as the force can damage the powder coating. Stick to gentle cleaning methods to ensure the longevity of the finish.

Hard water deposits can affect the appearance of the powder coating over time.

When the outdoor kitchen is not in use, consider using protective covers to shield it from the elements. This helps prevent exposure to harsh sunlight, rain, and other environmental factors that could impact the powder coating. If your area has hard water, consider wiping down the surfaces after rain or watering to prevent water spots.

## **Countertop Stone Maintenance**

Please take extra care when cleaning your countertop stone. Although solvents, such as acetone, are often recommended by counter manufacturers and fabricators, these substances will damage your BRABURA powder coated finish.

To clean your countertop stone, use soapy water and a damp cloth. If there are stains encrusted/dry, you have to soak the stain with a standard detergent and wait to rub with a damp cloth. Special consideration with ceramic knives which may scratch the stone's surface.

## **Fusion LITE Maintenance**

Full details on the care and maintenance of the Fusion LITE barbecue can be found in the specific instruction manual included in the packaging, under the "Cleaning your Appliance" section

Inspect the detailed warranty advises for more information at <https://www.braburagrills.com>

**ES** Para prolongar la vida útil de sus módulos de cocina LITE Series BRABURA, siga las instrucciones recomendadas de mantenimiento:

## **Superficies con Recubrimiento en Polvo**

La limpieza programada beneficiará y prolongará la estética duradera del acabado. Este procedimiento es parte integral de la garantía dada para el acabado superficial y la retención del color, y minimizará el efecto del envejecimiento causado por la suciedad y otros contaminantes transportados por el aire que tienden a acumularse en la superficie del recubrimiento, opacando su apariencia. Sugerimos las siguientes pautas:

- Limpie las superficies recubiertas con agua tibia y detergente suave o solución limpiadora no abrasiva pH-balanceada, y el uso de un cepillo o esponja no abrasivos.
- La solución de limpieza no debe estar en contacto con la superficie recubierta en polvo durante más de 30 minutos.
- NO use cloruros ni sales cuaternarias en el módulo. NO use ácido clorhídrico (ácido muriático) en los módulos. Evite el uso de productos químicos fuertes, solventes o limpiadores abrasivos, ya que pueden dañar el recubrimiento en polvo. Opte por limpiadores diseñados específicamente para superficies recubiertas en polvo.
- Después de la limpieza, enjuague completamente la superficie con agua limpia y fresca para eliminar cualquier residuo de limpieza. Esto ayuda a prevenir la acumulación de agentes de limpieza que podrían afectar el recubrimiento en polvo con el tiempo.
- Mantenga y documente un registro de todos los horarios de limpieza, frecuencias y productos.
- Aunque la limpieza es crucial, evite el uso de hidrolimpiadora de alta presión, ya que la fuerza puede dañar el recubrimiento en polvo. Opte por métodos de limpieza suaves para garantizar la longevidad del acabado.

Las acumulaciones de agua dura pueden afectar la apariencia del recubrimiento en polvo con el tiempo.

Cuando la cocina al aire libre no esté en uso, considere usar cubiertas protectoras para protegerla de los elementos. Esto ayuda a prevenir la exposición a la luz solar intensa, la lluvia y otros factores ambientales que podrían afectar el recubrimiento en polvo. Si su área tiene agua dura, considere limpiar las superficies después de la lluvia o el riego para prevenir manchas de agua.

## **Mantenimiento de la Encimera**

Tenga cuidado al limpiar su encimera. Evite solventes como acetona, ya que dañarán el acabado de recubrimiento en polvo de su cocina LITE Series BRABURA. Para limpiar su encimera, use agua jabonosa y un paño húmedo.

Para manchas incrustadas o secas, empape la mancha con detergente estándar y frótela con un paño húmedo.

Tenga especial consideración con los cuchillos cerámicos, pueden rayar la superficie de su encimera, al igual que rayan otras superficies.

## **Mantenimiento de las Fusion LITE**

Todos los detalles sobre el cuidado y mantenimiento de la barbacoa Fusion LITE se encuentran en el manual de instrucciones específico incluido en el embalaje, en la sección "Limpieza del producto".

Revise los detalles de la garantía para obtener más información en <https://www.braburagrills.com>

**DE** Um die Lebensdauer Ihrer BRABURA LITE Series kitchen zu verlängern, befolgen Sie bitte die empfohlenen Wartungsanweisungen:

## **Pulverbeschichtete Oberflächen**

Die geplante Reinigung wird von Vorteil sein und die lang anhaltende Ästhetik der Oberfläche verlängern.

Dieses Verfahren ist ein integraler Bestandteil der Garantie für Oberflächenfinish und Farbbeständigkeit, und es wird den Verwitterungseffekt von Schmutz und anderen luftgetragenen Schadstoffen minimieren, die dazu neigen, sich auf der Oberfläche der Beschichtung anzusammeln und ihr Aussehen zu mattieren. Wir schlagen folgende Richtlinien vor:

- Reinigung der beschichteten Oberflächen mit warmem Wasser und mildem Reinigungsmittel oder einer nicht abrasiven, pH-neutralen Reinigungslösung und Verwendung einer nicht abrasiven Bürste oder eines Schwamms.
- Die Reinigungslösung sollte nicht länger als 30 Minuten mit der pulverbeschichteten Oberfläche in Kontakt bleiben.
- VERWENDEN SIE KEINE Chloride oder quartäre Salze auf dem Modul. VERWENDEN SIE KEINE Salzsäure (Salzsäure) auf Modulen. Verzichten Sie auf den Einsatz von aggressiven Chemikalien, Lösungsmitteln oder scheuernden Reinigungsmitteln, da diese die Pulverbeschichtung beschädigen können. Entscheiden Sie sich für Reinigungsmittel, die speziell für pulverbeschichtete Oberflächen entwickelt wurden.
- Nach der Reinigung muss die Oberfläche vollständig mit sauberem Frischwasser abgespült werden, um alle Reinigungsrückstände zu entfernen. Dies hilft, die Ansammlung von Reinigungsmitteln zu verhindern, die im Laufe der Zeit die Pulverbeschichtung beeinträchtigen könnten.
- Ein Protokoll aller Reinigungspläne, -frequenzen und -produkte sollte geführt und dokumentiert werden.
- Obwohl die Reinigung wichtig ist, sollten Hochdruckreiniger vermieden werden, da die Kraft die Pulverbeschichtung beschädigen kann. Halten Sie sich an sanfte Reinigungsmethoden, um die Langlebigkeit des Finishs zu gewährleisten.

Ablagerungen von hartem Wasser können im Laufe der Zeit das Erscheinungsbild der Pulverbeschichtung beeinträchtigen.

Wenn die Außenküche nicht benutzt wird, sollten Schutzabdeckungen verwendet werden, um sie vor den Elementen zu schützen. Dadurch wird verhindert, dass sie Sonnenlicht, Regen und anderen Umweltfaktoren ausgesetzt wird, die die Pulverbeschichtung beeinträchtigen könnten. Wenn Ihr Bereich hartes Wasser hat, erwägen Sie, die Oberflächen nach Regen oder Bewässerung abzuwischen, um Wasserflecken zu vermeiden.

## **Reinigung der Arbeitsplatte**

Seien Sie vorsichtig beim Reinigen Ihrer Arbeitsplatte. Vermeiden Sie Lösungsmittel wie Aceton, da diese die pulverbeschichtete Oberfläche Ihrer LITE Series BRABURA-Küche beschädigen können. Zur Reinigung verwenden Sie Seifenwasser und ein feuchtes Tuch.

Bei eingetrockneten oder hartnäckigen Flecken tränken Sie die Stelle mit handelsüblichem Reinigungsmittel und reiben Sie vorsichtig mit einem feuchten Tuch. Besondere Vorsicht ist bei Keramikmessern geboten, da diese die Oberfläche der Arbeitsplatte zerkratzen können – wie auch andere empfindliche Oberflächen.

## **Fusion LITE Wartung**

Alle Informationen zur Pflege und Wartung des Fusion LITE Grills finden Sie in der dem Gerät beiliegenden Bedienungsanleitung im Abschnitt „Reinigung Ihres Geräts“.

Garantie und weitere Informationen unter <https://www.braburagrills.com>

## NETTOYAGE ET ENTRETIEN

**FR** Pour prolonger la durée de vie de vos BRABURA LITE Series kitchen, veuillez suivre les instructions d'entretien recommandées :

### Surfaces Revêtues de Poudre

L'entretien planifié bénéficiera et prolongera l'esthétique durable de la finition. Cette procédure fait partie intégrante de la garantie accordée pour la finition de surface et la rétention de la couleur, et elle minimisera l'effet de détérioration de la saleté et d'autres polluants atmosphériques qui ont tendance à s'accumuler à la surface du revêtement, ternissant son apparence. Nous suggérons les lignes directrices suivantes :

- Nettoyez les surfaces revêtues avec de l'eau tiède et un détergent doux ou une solution nettoyante non abrasive équilibrée en pH, et utilisez une brosse ou une éponge non abrasive.
- La solution de nettoyage ne doit pas rester en contact avec la surface recouverte de poudre pendant plus de 30 minutes.
- NE PAS utiliser de chlorures ni de sels quaternaires sur le module. NE PAS utiliser d'acide chlorhydrique (acide muriatique) sur les modules. Évitez d'utiliser des produits chimiques agressifs, des solvants ou des nettoyants abrasifs, car ils peuvent endommager le revêtement en poudre. Optez pour des nettoyants spécialement conçus pour les surfaces revêtues de poudre.
- Après le nettoyage, rincez complètement la surface à l'eau fraîche et propre pour éliminer tout résidu de nettoyage. Cela contribue à prévenir l'accumulation d'agents de nettoyage qui pourraient affecter le revêtement en poudre avec le temps.
- Un registre de tous les horaires de nettoyage, fréquences et produits doit être conservé et documenté.
- Bien que le nettoyage soit crucial, évitez d'utiliser des nettoyeurs haute pression, car la force peut endommager le revêtement en poudre. Suivez des méthodes de nettoyage douces pour assurer la longévité de la finition.

Les dépôts de calcaire peuvent affecter l'apparence du revêtement en poudre avec le temps.

Lorsque la cuisine extérieure n'est pas utilisée, envisagez d'utiliser des couvertures de protection pour la protéger des éléments. Cela aide à éviter l'exposition à la lumière solaire intense, à la pluie et à d'autres facteurs environnementaux qui pourraient affecter le revêtement en poudre. Si votre région a de l'eau dure, envisagez de nettoyer les surfaces après la pluie ou l'arrosage pour éviter les taches d'eau.

### Entretien du Plan de Travail

Veuillez prendre des précautions supplémentaires lors du nettoyage de votre dessus en plan de travail . Évitez les solvants tels que l'acétone, car ils peuvent endommager la finition thermolaquée de votre cuisine LITE Series BRABURA.

Pour le nettoyage, utilisez de l'eau savonneuse et un chiffon humide.

Pour les taches sèches ou incrustées, imbitez la zone avec un détergent standard et frottez délicatement avec un chiffon humide.

Soyez particulièrement prudent avec les couteaux en céramique, car ils peuvent rayer la surface du plan de travail, comme sur d'autres surfaces.

### Entretien du modèle Fusion LITE

Tous les détails concernant le soin et l'entretien du barbecue Fusion LITE se trouvent dans le manuel d'instructions spécifique fourni dans l'emballage, à la section «Nettoyage du Produit».

Consultez les conseils détaillés de garantie pour plus d'informations sur <https://www.braburagrills.com>

## PULIZIA E MANUTENZIONE

**IT** Per prolungare la vita dei BRABURA LITE Series kitchen, segui le istruzioni di manutenzione consigliate:

### **Superfici Verniciate a Polvere**

La pulizia programmata avrà benefici e prolungherà l'estetica duratura della finitura. Questa procedura è parte integrante della garanzia fornita per la finitura superficiale e il mantenimento del colore e minimizzerà l'effetto di deterioramento della polvere causato da sporco e altri agenti inquinanti atmosferici che tendono ad accumularsi sulla superficie della rivestimento, opacizzandone l'aspetto. Suggeriamo le seguenti linee guida:

- Pulizia delle superfici rivestite con acqua calda e detergente delicato o soluzione detergente pH neutro non abrasiva, utilizzando una spazzola o una spugna non abrasive.
- La soluzione detergente non dovrebbe rimanere a contatto con la superficie rivestita a polvere per più di 30 minuti.
- NON utilizzare cloruri o sali quaternari sul modulo. NON utilizzare acido cloridrico (acido muriatico) sui moduli. Evitare l'uso di sostanze chimiche aggressive, solventi o detersivi abrasivi, poiché possono danneggiare il rivestimento a polvere. Optare per detersivi specificamente progettati per superfici rivestite a polvere.
- Dopo la pulizia, la superficie deve essere completamente sciacquata con acqua fresca pulita per rimuovere eventuali residui di pulizia. Questo aiuta a prevenire l'accumulo di agenti di pulizia che potrebbero influenzare nel tempo il rivestimento a polvere.
- Si consiglia di mantenere e documentare un registro di tutti gli orari di pulizia, le frequenze e i prodotti utilizzati.
- Anche se la pulizia è fondamentale, evitare di utilizzare idropulitrici ad alta pressione, poiché la forza potrebbe danneggiare il rivestimento a polvere. Utilizzare metodi di pulizia delicati per garantire la longevità della finitura.

I depositi di calcare possono influenzare l'aspetto del rivestimento a polvere nel tempo.

Quando la cucina esterna non è in uso, considerare l'utilizzo di coperture protettive per proteggerla dagli agenti atmosferici. Questo aiuta a prevenire l'esposizione alla luce solare diretta, alla pioggia e ad altri fattori ambientali che potrebbero influenzare il rivestimento a polvere. Se la zona è soggetta ad acqua dura, considerare di asciugare le superfici dopo la pioggia o l'irrigazione per prevenire la formazione di macchie d'acqua.

### **Manutenzione della Pietra Neolith**

Si prega di prestare particolare attenzione durante la pulizia della tua pietra Neolith. Anche se i solventi, come l'acetone, sono spesso raccomandati dai produttori e dai fabbricanti di piani, queste sostanze danneggiano la finitura verniciata a polvere del tuo modulo BRABURA LITE Series kitchen.

Per pulire il piano di lavoro in pietra, usa acqua saponata e un panno umido. Se ci sono macchie incrostate/asciutte, è necessario inumidire la macchia con un detergente standard e attendere per strofinare con un panno umido. Prestare particolare attenzione ai coltelli in ceramica che potrebbero graffiare la superficie della Neolith in ogni finitura, allo stesso modo in cui graffiano altre superfici.

### **Manutenzione Fusion LITE**

Tutti i dettagli relativi alla cura e alla manutenzione del barbecue Fusion LITE sono disponibili nel manuale di istruzioni specifico incluso nella confezione, nella sezione "Pulizia del tuo elettrodomestico".

Consultare le dettagliate informazioni sulla garanzia per ulteriori dettagli su <https://www.braburagrills.com>

# WARRANTY

GARANTÍA/ GARANTIE / GARANTIE / GARANZIA

**BRABURA**  
GRILLS

Drawer guides and hinges	2 years
Guías y bisagras de cajones	2 años
Führungen und Scharniere der Schubladen	2 Jahre
Guides et charnières des tiroirs	2 ans
Guide e cerniere dei cassetti	2 anni

Painted finishes	3 years
Acabados pintados	3 años
Bemalte Oberflächen	3 Jahre
Pintures finies	3 ans
Finiture verniciate	3 anni

Overall structural integrity	10 years
Integridad estructural general	10 años
Generelle strukturelle Integrität	10 Jahre
Intégrité structurelle générale	10 ans
Integrità strutturale generale	10 anni

Refrigerator	2 years
Frigorífico	2 años
Kühlschrank	2 Jahre
Réfrigérateur	2 ans
Frigorifero	2 anni

Stone countertops	3 years
Encimera	3 años
Arbeitsplatte	3 Jahre
Plans de travail	3 ans
Piani di lavoro	3 anni

**EN** **Contact:** Tel: +34 667 37 48 74 / warranty@braburagrills.com / Correspondence to: Brabura Grills SL, Calle Acero, 12 - 06220 – Villafranca de los Barros (Badajoz), Spain.

Brabura product owners who purchased through Brabura dealers can register their warranty at <https://www.braburagrills.com>

**ES** **Consultas:** Tel. +34 667 37 48 74 / warranty@braburagrills.com / Correspondencia: Brabura Grills SL, Calle Acero, 12 - 06220 – Villafranca de los Barros (Badajoz), España.

Los propietarios de productos Brabura que hayan adquirido a través de distribuidores de Brabura pueden registrar su garantía en <https://www.braburagrills.com>

**DE** **Kontakt:** Tel: +34 667 37 48 74 / warranty@braburagrills.com / Korrespondenz an: Brabura Grills SL, Calle Acero, 12 - 06220 – Villafranca de los Barros (Badajoz), Spanien.

Besitzer von Brabura-Produkten, die über Brabura-Händler gekauft wurden, können ihre Garantie unter <https://www.braburagrills.com> registrieren.

**FR** **Contact :** Tél. : +34 667 37 48 74 / warranty@braburagrills.com / Correspondance à : Brabura Grills SL, Calle Acero, 12 - 06220 – Villafranca de los Barros (Badajoz), Espagne.

Les propriétaires de produits Brabura achetés auprès des revendeurs Brabura peuvent enregistrer leur garantie sur <https://www.braburagrills.com>

**IT** **Contatto:** Tel: +34 667 37 48 74 / warranty@braburagrills.com / Corrispondenza a: Brabura Grills SL, Calle Acero, 12 - 06220 – Villafranca de los Barros (Badajoz), Spagna.

I proprietari di prodotti Brabura che hanno acquistato attraverso rivenditori Brabura possono registrare la loro garanzia su <https://www.braburagrills.com>

**Share Life**  
Share Experiences

visit [braburagrills.com](https://braburagrills.com)

---

CALLE ACERO 12 | 06220 VILAFRANCA DE LOS BARROS (BADAJOZ) | SPAIN